

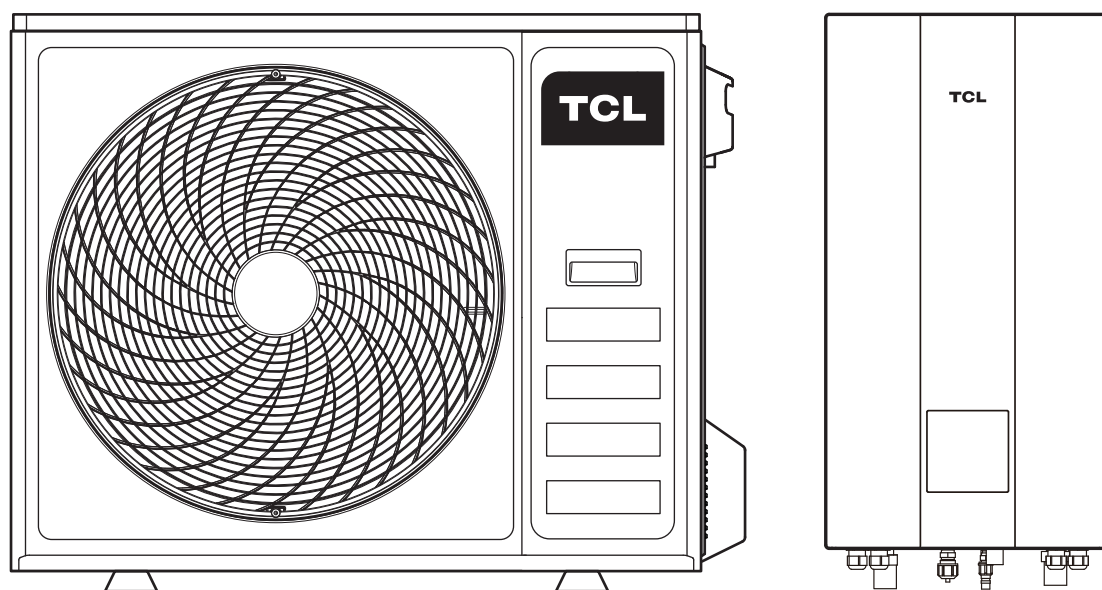

# INSTALLATION AND OWNER'S MANUAL

Air to Water Heat Pump System Tri-Thermal Split



**IMPORTANT NOTE:**

Thank you very much for purchasing our product.  
Before using your unit, please read this manual carefully and keep it for future reference.

# CONTENTS

1 SAFETY PRECAUTIONS .....	01
2 BEFORE INSTALLATION.....	07
3 IMPORTANT INFORMATION FOR THE REFRIGERANT .....	07
4 INSTALLATION SITE.....	07
5 INSTALLATION PRECAUTIONS .....	10
6 INSTALLATION OF OUTDOOR UNIT CONNECTING PIPES .....	13
7 OVERVIEW OF THE UNIT.....	15
8 TEST RUN AND FINAL CHECKS .....	28
9 PRECAUTIONS ON REFRIGERANT LEAKAGE .....	28
10 MAINTENANCE AND SERVICE .....	29
11 TURN OVER TO CUSTOMER .....	30
12 OPERATION AND PERFORMANCE.....	31
13 ERROR CODES.....	32
14 TECHNICAL SPECIFICATIONS.....	37
15 INFORMATION SERVICING.....	39

# 1 SAFETY PRECAUTIONS

---

The precautions listed here are divided into the following types. They are quite important, so be sure to follow them carefully. Read these instructions carefully before installation. Keep this manual well for future reference.

Meanings of DANGER, WARNING, CAUTION and NOTE symbols.

## INFORMATION

- Read these instructions carefully before installation. Keep this manual handy for future reference.
- Improper installation of equipment or accessories may result in electric shock, short-circuit, leakage, fire or other damage to the equipment.
- Be sure to only use accessories made by the supplier, which are specifically designed for the equipment and ensure that the installation is completed by professionals.
- All the activities described in this manual must be carried out by licensed technicians. Be sure to wear adequate personal protection equipment such as gloves and safety glasses while installing the unit or carrying out maintenance activities.
- Contact your dealer for any further assistance.

## DANGER

Indicates an imminently hazardous situation which if not avoided, will result in death or serious injury.

## WARNING

Indicates a potentially hazardous situation which if not avoided, could result in death or serious injury.

## CAUTION

Indicates a potentially hazardous situation which if not avoided, may result in minor or moderate injury. It is also used to alert against unsafe practices.

## NOTE

Indicates situations that could only result in accidental equipment or property damage.

## WARNING

- Improper installation of equipment or accessories may result in electric shock, short-circuit, leakage, fire or other damage to the equipment. Be sure to only use accessories made by the supplier, which are specifically designed for the equipment and make sure to get installation done by a certified person.
- All the activities described in this manual must be carried out by a licensed technician. Be sure to wear adequate personal protection equipment such as gloves and safety glasses while installing the unit or carrying out maintenance activities.



Caution: Risk of fire/  
flammable materials

**! WARNING**

Servicing shall only be performed as recommended by the equipment manufacturer. Maintenance and repair requiring the assistance of other skilled personnel shall be carried out under the supervision of the person competent in the use of flammable refrigerants.

**Special requirements for R32**

**! WARNING**

- Do not have refrigerant leakage and open flame.
- Be aware that the R32 refrigerant does NOT contain an odour.

**! WARNING**

The appliance shall be stored so as to prevent mechanical damage and in a well-ventilated room without continuously operating ignition sources (example: open flames, an operating gas appliance) and have a room size as specified below.

**! WARNING**

Make sure installation, servicing, maintenance and repair comply with instruction and with applicable legislation (for example national gas regulation) and are executed only by authorized persons.

**💡 NOTE**

- Pipework should be protected from physical damage.
- Installation of pipework shall be kept to a minimum length.

If the total refrigerant charge in the system is <1.84 kg (i.e. if the piping length is <15m for 12/14/16kW), there are no additional minimum floor area requirement.

If the total refrigerant charge in the system is ≥1.84 kg (i.e. if the piping length is ≥15m for 12/14/16kW), you need to comply with additional minimum floor area requirements as described in the following flow chart. The flow chart uses the following tables: "Table 1-Maximum refrigerant charge allowed in a room: indoor unit" on page 4, "Table 2-Minimum floor area: indoor unit" on page 4 and "Table 3-Minimum venting opening area for natural ventilation: indoor unit" on page 4.

If the piping length is 30m, then the minimum floor area is ≥4.5m<sup>2</sup>; if the floor area is less than 4.5m<sup>2</sup>, it needs to be trepanning a hole of 200cm<sup>2</sup>.

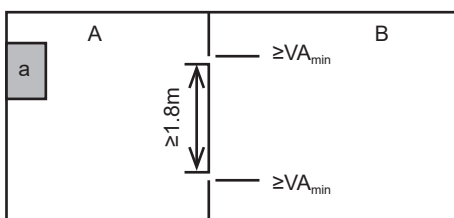

a Indoor unit  
A Room where the indoor unit is installed.  
B Room adjacent to room A.

The area of A plus B has to be greater than or equal to 4.5 m<sup>2</sup>.

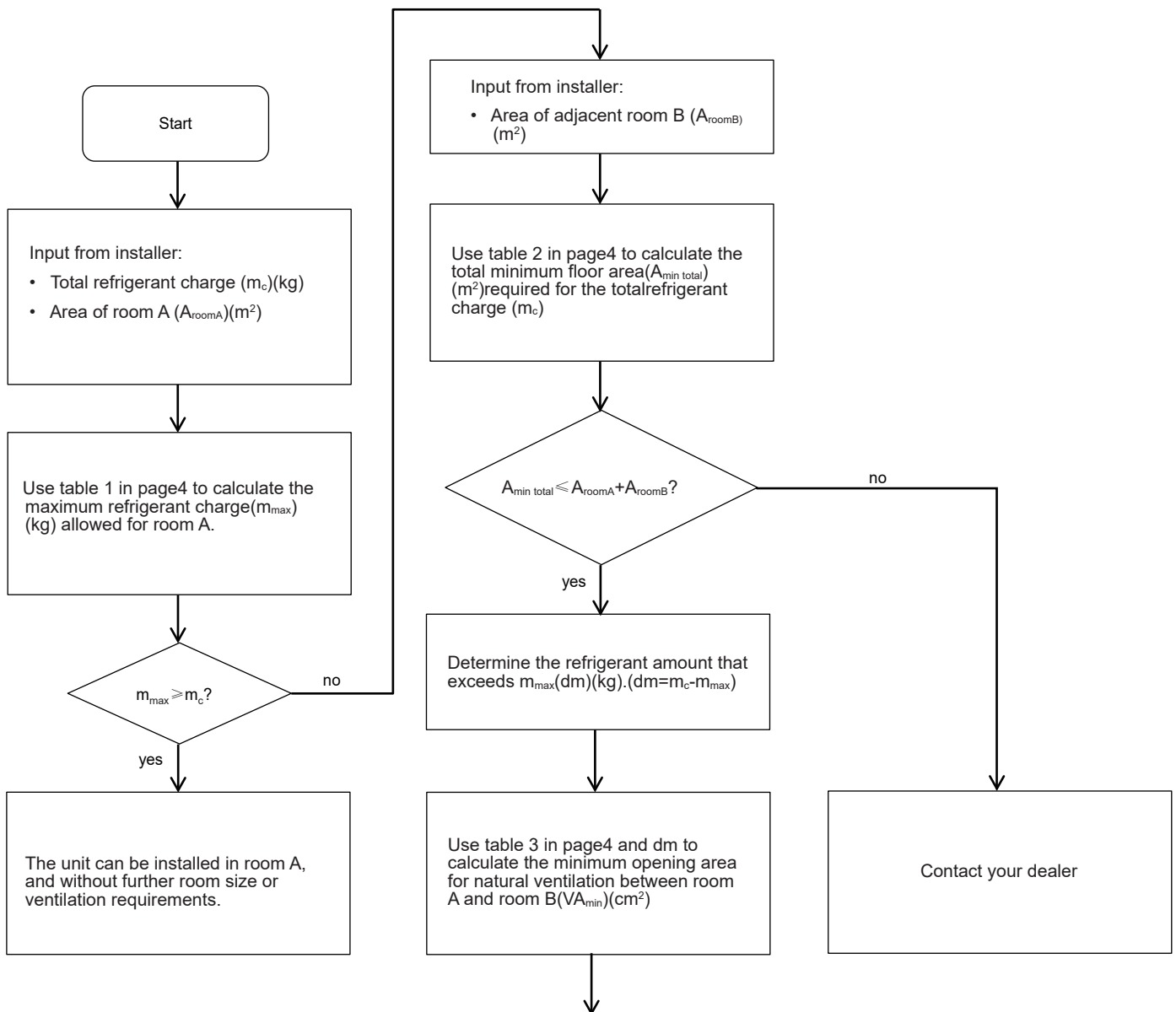

Unit can be installed at room A if:

- 2 ventilation openings (permanently open) are provided between room A and B, 1 at the top and 1 at the bottom.
- Bottom opening: The bottom opening must meet the minimum area requirements ( $V_{A_{min}}$ ). It must be as close as possible to the floor. If the ventilation opening starts from the floor, the height must be  $\geq 20\text{mm}$ . The bottom of the opening must be situated  $\leq 100\text{mm}$  from the floor.
- At least 50% of the required opening area must be situated  $< 200\text{ mm}$  from the floor. The entire area of the opening must be situated  $< 300\text{ mm}$  from the floor.
- Top opening: The area of the top opening must be larger than or equal to the bottom opening. The bottom of the top opening must be situated at least  $1.5\text{m}$  above the top of the bottom opening.
- Ventilation openings to the outside are NOT considered suitable ventilation openings (the user can block them when it is cold).

**Table 1 Maximum refrigerant charge allowed in a room:indoor unit**

A <sub>room</sub> (m <sup>2</sup> )	Maximum refrigerant charge in a room(mmax)(kg)	A <sub>room</sub> (m <sup>2</sup> )	Maximum refrigerant charge in a room(mmax)(kg)
	H=1800mm		H=1800mm
1	1.02	4	2.05
2	1.45	5	2.29
3	1.77	6	2.51

**NOTE**

- For wall mounted models, the value of "Installation height (H)" is considered 1800 mm to comply to IEC 60335-2-40:2013 A1 2016 Clause GG2.
- For intermediate A<sub>room</sub> values(i.e. when A<sub>room</sub> is between two values from the table), consider the value that corresponds to the lower A<sub>room</sub> value from the table. If A<sub>room</sub> =3.5m<sup>2</sup>, consider the value that corresponds to "A<sub>room</sub> =3m<sup>2</sup>".

**Table 2-Minimum floor area:indoor unit**

m <sub>c</sub> (kg)	Minimum floor area(m <sup>2</sup> )
	H=1800mm
1.84	3.32
2.00	3.81
2.25	4.83
2.50	5.96

**NOTE**

- For wall mounted models, the value of "Installation height (H)" is considered 1800 mm to comply to IEC 60335-2-40:2013 A1 2016 Clause GG2.
  - For intermediate m<sub>c</sub> values(i.e. when m<sub>c</sub> is between two values from the table), consider the value that corresponds to the higher m<sub>c</sub> value from the table. If m<sub>c</sub> =1.87kg, consider the value that corresponds to "m<sub>c</sub> =2kg".
- Systems with total refrigerant charge lower than 1.84kg are not subjected to any room requirements.





**Table 3 Maximum refrigerant charge allowed in a room:indoor unit**

m <sub>c</sub>	m <sub>max</sub>	dm=m <sub>c</sub> -m <sub>max</sub> (kg)	Minimum venting opening area(cm <sup>2</sup> )
			H=1800mm
2.22	0.1	2.12	495.14
2.22	0.3	1.92	448.43
2.22	0.5	1.72	401.72
2.22	0.7	1.52	355.01
2.22	0.9	1.32	308.30
2.22	1.1	1.12	261.59
2.22	1.3	0.92	214.87
2.22	1.5	0.72	168.16
2.22	1.7	0.52	121.45
2.22	1.9	0.32	74.74
2.22	2.1	0.12	28.03

**NOTE**

- For wall mounted models, the value of "Installation height (H)" is considered 1800 mm to comply to IEC 60335-2-40:2013 A1 2016 Clause GG2.
- For intermediate dm values(i.e. when dm is between two values from the table), consider the value that corresponds to the higher dm value from the table. If dm =1.55kg, consider the value that corresponds to "dm =1.72kg".

## Explanation of symbols displayed on the indoor unit or outdoor unit

	WARNING	This symbol shows that this appliance used a flammable refrigerant. If the refrigerant is leaked and exposed to an external ignition source, there is a risk of fire.
	CAUTION	This symbol shows that the operation manual should be read carefully.
	CAUTION	This symbol shows that service personnel should handle this equipment with reference to the installation manual.
	CAUTION	This symbol shows that a service personnel should be handling this equipment with reference to the installation manual.
	CAUTION	This symbol shows that information is available such as the operating manual or installation manual.

### DANGER

- Before touching electric terminal parts, turn off power switch.
- When service panels are removed, live parts can be easily touched by accident.
- Never leave the unit unattended during installation or servicing when the service panel is removed.
- Do not touch water pipes during or immediately after operation as the pipes may be hot and could burn your hands. To avoid injury, wait until the pipes cool down to ordinary temperature or be sure to wear protective gloves.
- Do not touch any switch with wet hands. Touching the switch with wet hands can cause electrical shock.
- Before touching electrical parts, turn off all applicable power to the unit.

### WARNING

- Tear apart and throw away plastic packaging bags so that children will not play with them. Children playing with plastic bags face danger of death by suffocation.
- Safely dispose of packing materials such as nails, other metal and wood parts that could cause injuries.
- Ask your dealer or qualified personnel to perform installation work in accordance with this manual. Do not install the unit by yourself. Improper installation could result in water leakage, electric shocks or fire.
- Be sure to use only specified accessories and parts for installation work. Failure to use specified parts may result in water leakage, electric shocks, fire, or the unit falling from its mount.
- Install the unit on a foundation that can withstand its weight. Insufficient physical strength may cause the equipment to fall and possible cause injury.
- Perform specified installation work with full consideration of strong wind, hurricanes, or earthquakes. Improper installation work may result in accidents due to equipment falling.
- Make certain that all electrical work is carried out by qualified personnel according to the local laws and regulations and this manual using a separate circuit. Insufficient capacity of the power supply circuit or improper electrical construction may lead to electric shocks or fire.
- Be sure to install a ground fault circuit interrupter according to local laws and regulations. Failure to install a ground fault circuit interrupter may cause electric shocks and fire.
- Make sure all wirings are secure. Use the specified wires and ensure that terminal connections or wires are protected from water and other adverse external forces. Incomplete connection or affixing may cause a fire.
- When wiring the power supply, form the wires so that the front panel can be securely fastened. If the front panel is not in place there could be overheating of the terminals, electric shocks or fire.
- After completing the installation work, check to make sure that there is no refrigerant leakage.
- Never directly touch any leaking refrigerant as it could cause severe frostbite. Do not touch the refrigerant pipes during or immediately after operation as the refrigerant pipes may be hot or cold, depending on the condition of the refrigerant flowing through the refrigerant piping, compressor and other refrigerant cycle parts. Burns or frostbite are possible if you touch the refrigerant pipes. To avoid injury, give the pipes time to return to normal temperature. If you must touch them, be sure to wear protective gloves.
- Do not touch the internal parts (pump, backup heater, etc.) during or immediately after operation. Touching the internal parts will cause burns. To avoid injury, give the internal parts time to return to normal temperature. If you must touch them, be sure to wear protective gloves.

## CAUTION

- Ground the unit.
- Grounding resistance should be according to local laws and regulations.
- Do not connect the ground wire to gas or water pipes, lightning conductors or telephone ground wires.
- Incomplete grounding may cause electric shocks.
  - Gas pipes: Fire or an explosion may occur if the gas leaks.
  - Water pipes: Hard vinyl tubes are not effective grounds.
  - Lightning conductors or telephone ground wires: Electrical threshold may rise abnormally if struck by a lightning bolt.
- Install the power wire at least 3 feet (1 meter) away from televisions or radios to prevent interference or noise. (Depending on the radio waves, a distance of 3 feet (1 meter) may not be sufficient to eliminate the noise.)
- Do not wash the unit. This may cause electric shocks or fire. The appliance must be installed in accordance with national wiring regulations. If the supply cord is damaged, it must be replaced by the manufacturer, its service agent or similarly qualified persons in order to avoid a hazard.
- Do not install the unit in the following places:
  - Where there is mist of mineral oil, oil spray or vapors. Plastic parts may deteriorate, and make them become loose or water leakage.
  - Where corrosive gases (such as sulphurous acid gas) are produced. Where corrosion of copper pipes or soldered parts may cause refrigerant to leak.
  - Where there is machinery which emits electromagnetic waves. Electromagnetic waves can disturb the control system and cause equipment malfunction.
  - Where flammable gases may leak, where carbon fiber or ignitable dust is suspended in the air or where volatile flammables such as paint thinner or gasoline are handled. These types of gases might cause a fire.
  - Where the air contains high levels of salt such as near the ocean.
  - Where voltage fluctuates a lot, such as in factories.
  - In vehicles or vessels.
  - Where acidic or alkaline vapors are present.
- This appliance can be used by children 8 years old and above and persons with reduced physical, sensory or mental capabilities or lack of experience and knowledge if they are supervised or given instruction on using the unit in a safe manner and understand the hazards involved. Children should not play with the unit. Cleaning and user maintenance should not be done by children without supervision.
- Children should be supervised to ensure that they do not play with the appliance.
- If the supply cord is damaged, it must be replaced by the manufacturer or its service agent or a similarly qualified person.
- DISPOSAL: Do not dispose this product as unsorted municipal waste. Collection of such waste separately for special treatment is necessary. Do not dispose of electrical appliances as municipal waste, use separate collection facilities. Contact your local government for information regarding the collection systems available. If electrical appliances are disposed of in landfills or dumps, hazardous substance can leak into the groundwater and get into the food chain, damaging your health and well-being.
- The wiring must be performed by certified person technicians in accordance with national wiring regulation and this circuit diagram. An all-pole disconnection device which has at least 3mm separation distance in all pole and a residualcurrent device(RCD) with the rating not exceeding 30mA shall be incorporated in the fixed wiring according to the national rule.
- Confirm the safety of the installation area ( walls, floors, etc. ) without hidden dangers such as water, electricity, and gas before wiring/pipes.
- Before installation, check whether the user's power supply meets the electrical installation requirements of unit ( including reliable grounding, leakage, and wire diameter electrical load, etc. ). If the electrical installation requirements of the product are not met, the installation of the product is prohibited until the product is rectified.
- Product installation should be fixed firmly. Take reinforcement measures when necessary.

## NOTE

- About Fluorinated Gases
  - This heat pump contains fluorinated gases. For specific information on the type of gas and the amount, please refer to the relevant label on the unit itself. Compliance with national gas regulations shall be observed.
  - Installation, service, maintenance and repair of this unit must be performed by a certified technician.
  - Product uninstallation and recycling must be performed by a certified technician.
  - If the system has a leak-detection system installed, it must be checked for leaks at least every 12 months. When the unit is checked for leaks, proper record-keeping of all checks is strongly recommended.



## 2 BEFORE INSTALLATION

---

### Before installation

Be sure to confirm the model name and the serial number of the unit.

#### CAUTION

##### Frequency of Refrigerant Leakage Checks

- For unit that contains fluorinated greenhouse gases in quantities of 5 tonnes of CO<sub>2</sub> equivalent or more, but of less than 50 tonnes of CO<sub>2</sub> equivalent, at least every 12 months, or where a leakage detection system is installed, at least every 24 months.
- For unit that contains fluorinated greenhouse gases in quantities of 50 tonnes of CO<sub>2</sub> equivalent or more, but of less than 500 tonnes of CO<sub>2</sub> equivalent at least every six months, or where a leakage detection system is installed, at least every 12 months.
- For unit that contains fluorinated greenhouse gases in quantities of 500 tonnes of CO<sub>2</sub> equivalent or more, at least every three months, or where a leakage detection system is installed, at least every six months.
- This heat pump is a hermetically sealed equipment that contains fluorinated greenhouse gases.
- Only certificated person is allowed to do installation, operation and maintenance.

## 3 IMPORTANT INFORMATION FOR THE REFRIGERANT

---

This product has the fluorinated gas, it is forbidden to release to air.

Refrigerant type: R32; Volume of GWP: 675.

GWP=Global Warming Potential

Model	Factory charged refrigerant volume in the unit	
	Refrigerant/kg	Tonnes CO <sub>2</sub> equivalent
3-phase 12kW	1.84	1.24
3-phase 14kW	1.84	1.24
3-phase 16kW	1.84	1.24

#### CAUTION

- Frequency of Refrigerant Leakage Checks
  - Equipment that contains less than 3 kg of fluorinated greenhouse gases or hermetically sealed equipment, which is labelled accordingly and contains less than 6 kg of fluorinated greenhouse gases shall not be subject to leak checks.
  - For unit that contains fluorinated greenhouse gases in quantities of 5 tonnes of CO<sub>2</sub> equivalent or more, but of less than 50 tonnes of CO<sub>2</sub> equivalent, at least every 12 months, or where a leakage detection system is installed, at least every 24 months.
  - Only certificated person is allowed to do installation, operation and maintenance.

## 4 INSTALLATION SITE

---

#### WARNING

- There is flammable refrigerant in the unit and it should be installed in a well-ventilated site. If the unit is installed inside, an additional refrigerant detection device and ventilation equipment must be added in accordance with the standard EN378. Be sure to adopt adequate measures to prevent the unit from being used as a shelter by small animals.
- Small animals making contact with electrical parts can cause malfunction, smoke or fire. Please instruct the customer to keep the area around the unit clean.
- The equipment is not intended for use in a potentially explosive atmosphere.

Select an installation site where the following conditions are satisfied and one that meets with your customer's approval.

- Places that are well-ventilated.
- Places where the unit does not disturb next-door neighbors.
- Safe places which can bear the unit's weight and vibration and where the unit can be installed at an even level.
- Places where there is no possibility of flammable gas or product leak.
- The equipment is not intended for use in a potentially explosive atmosphere.
- Places where servicing space can be well ensured.
- Places where the units' piping and wiring lengths come within the allowable ranges.
- Places where water leaking from the unit cannot cause damage to the location (e.g. in case of a blocked draining pipe).
- Places where rain can be avoided as much as possible.
- Do not install the unit in places often used as a work space. In case of construction work (e.g. grinding etc.) where a lot of dust is created, the unit must be covered.
- Do not place any object or equipment on top of the unit (top plate).
- Do not climb, sit or stand on top of the unit.
- Be sure that sufficient precautions are taken in case of refrigerant leakage according to relevant local laws and regulations.- Don't install the unit near the sea or where there is corrosion gas.

When installing the unit in a place exposed to strong wind, pay special attention to the following.

Strong winds of 5 m/sec or more blowing against the unit's air outlet causes a short circuit (suction of discharge air), and this may have the following consequences:

- Deterioration of the operational capacity.
- Frequent frost acceleration in heating operation.
- Disruption of operation due to rise of high pressure.
- Motor burnout.
- When a strong wind blows continuously on the front of the unit, the fan can start rotating very fast until it breaks.

## 4.1 Installation Site of indoor unit

### CAUTION

The indoor unit should be installed in an indoor water proof place, or the safety of the unit and the operator cannot be ensured.

The indoor unit is to be wall mounted in an indoor location that meets the following requirements:

- The installation location is frost-free.
- The space around the unit is adequate for serving.
- The space around the unit allows for sufficient air circulation.
- There is a provision for condensate drain and pressure relief valve blow-off.

### CAUTION

When the unit running in the cooling mode, condensate may drop from the water inlet and water outlet pipes. Please make sure the dropping condensate will not result in damage of your furniture and other devices.

- The installation surface is a flat and vertical non-combustible wall, capable of supporting the operation weight of the unit.
- All piping lengths and distance have been taken into consideration.

Requirement	Value
Maximum allowable piping length between the 3-way valve SV1 and the indoor unit (only for installations with domestic hot water tank)	3m
Maximum allowable piping length between the domestic hot water tank and the indoor unit (only for installations with domestic hot water tank). The temperature sensor cable supplied with the indoor unit is 10m in length.	8m
Maximum allowable piping length between the TW2 and the indoor unit. The temperature sensor a cable of TW2 supplied with the indoor unit is 10m in length.	8m

## 4.2 Installation Site of Outdoor unit

In normal condition, refer to the figures below for installation of the unit:

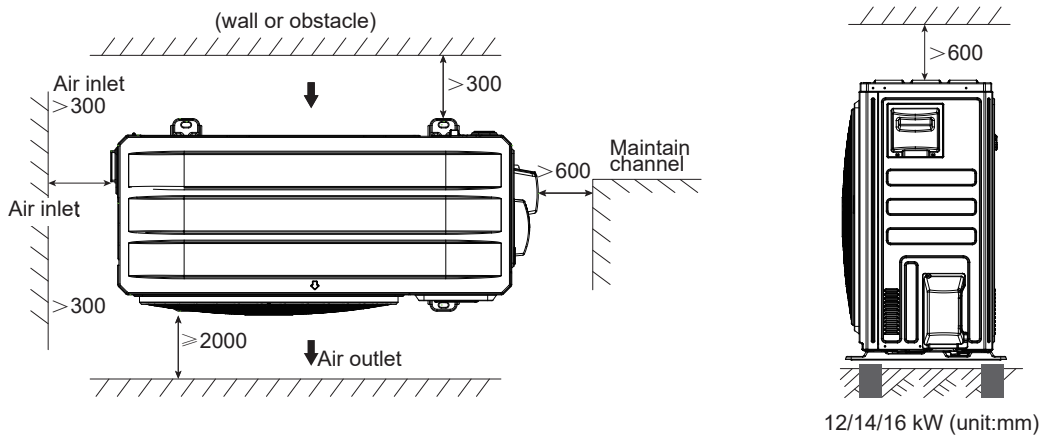

### NOTE

- Make sure there is enough space to do the installation. Set the outlet side at a right angle to the direction of the wind.
- Prepare a water drainage channel around the foundation, to drain waste water from around the unit.
- If water does not easily drain from the unit, mount the unit on a foundation of concrete blocks, etc. (the height of the foundation should be about 100 mm .
- When installing the unit in a place frequently exposed to snow, pay special attention to elevate the foundation as high as possible.
- If you install the unit on a building frame, please install a waterproof plate (field supply) (about 100mm, on the underside of the unit) in order to avoid drain water dripping. (See the picture in the right).

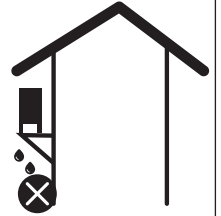

### 4.2.1 Selecting a location in cold climates

#### NOTE

When operating the unit in cold climates, be sure to follow the instructions described below.

- To prevent exposure to wind, install the unit with its suction side facing the wall.
- Never install the unit at a site where the suction side may be exposed directly to wind.
- To prevent exposure to wind, install a baffle plate on the air discharge side of the unit.
- In heavy snowfall areas, it is very important to select an installation site where the snow will not affect the unit. If lateral snowfall is possible, make sure that the heat exchanger coil is not affected by the snow (if necessary construct a lateral canopy).

### 4.2.2 Prevent sunshine

As the outdoor temperature is measured via the outdoor unit air thermistor, make sure to install the outdoor unit in the shade or a canopy should be constructed to avoid direct sunlight, so that it is not influenced by the sun's heat, otherwise protection may be possible to the unit.

#### WARNING

Uncovered scene, anti-snow shed must be installed:

- (1) To prevent rain and snow from hitting the heat exchanger, resulting in poor heating capacity of the unit, after long time accumulation, the heat exchanger freezes;
- (2) To prevent the outdoor unit air thermistor from being exposed to the sun, resulting in failure to boot;
- (3) To prevent freezing rain.

# 5 INSTALLATION PRECAUTIONS

## 5.1 Installation precautions of indoor unit

### 5.1.1 Dimensions

Dimensions of the wall bracket:

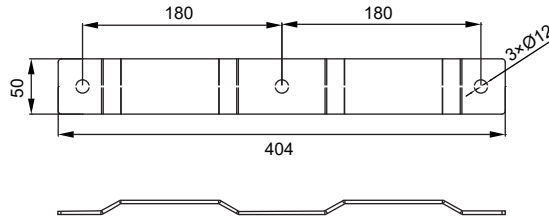

### 5.1.2 Dimensions of the unit:

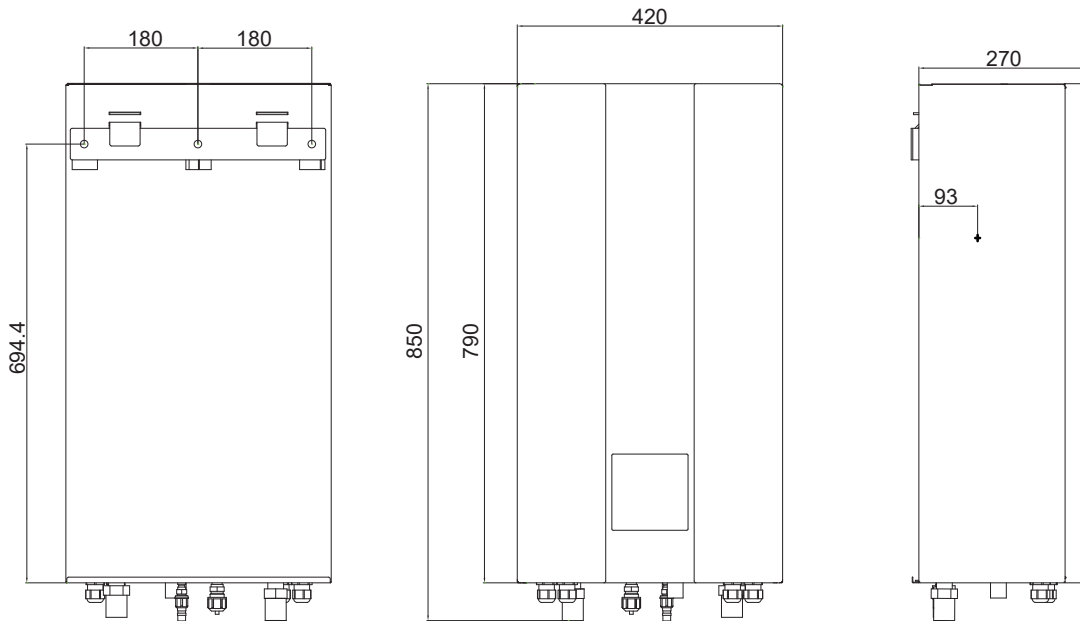
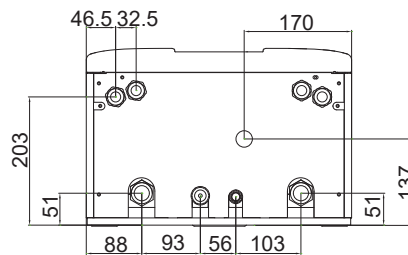

### 5.1.2 Installation requirements

- The indoor unit is packed in a box.
- During delivery, the unit must be checked and any damage must be reported immediately to the carrier claims agent.
- Check if all indoor unit accessories are enclosed.
- Bring the unit as close as possible to the final installation position in its original package in order to prevent damage during transport.
- The indoor unit weight is approximately 50kg and should be lifted by two persons.

### WARNING

Do not grasp the control box or pipe to lift the unit!

### 5.1.3 Servicing space requirements

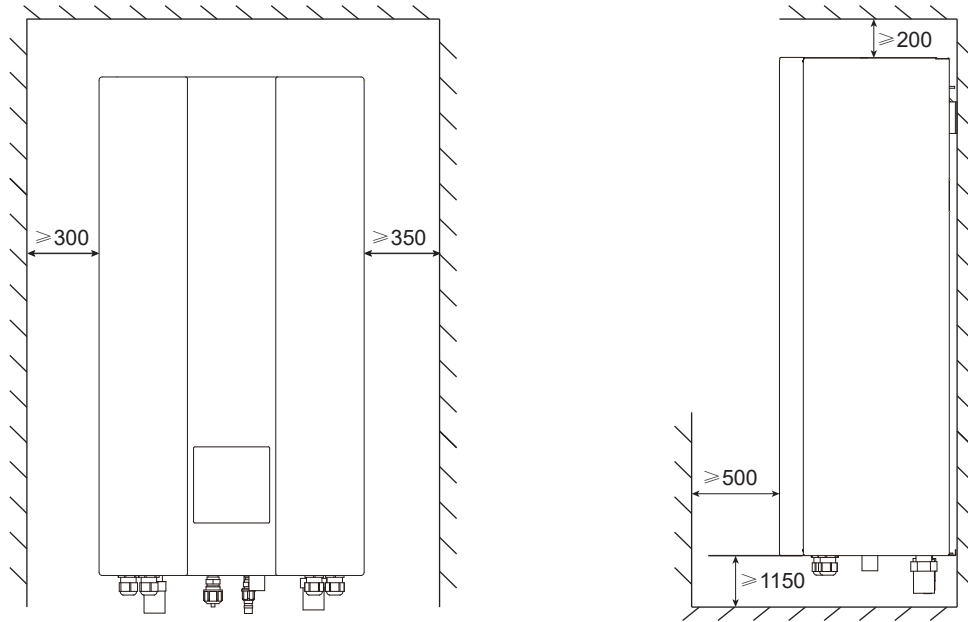

unit:mm

### 5.1.4 Mounting the indoor unit

- Fix the wall mounting bracket to the wall using appropriate plugs and screws.
- Make sure the wall mounting bracket is horizontal level.
- Pay special attention to prevent overflow of the drain pan.
- Hang the indoor unit on the wall mounting bracket.

### 5.1.5 Refrigerant pipe connection

- Align the center of the pipes
- Sufficiently tighten the flare nut with fingers, and then tighten it with a spanner and torque wrench.
- The protective nut is a one-time part, it can not be reused. In case it is removed, it should be replaced with a new one.

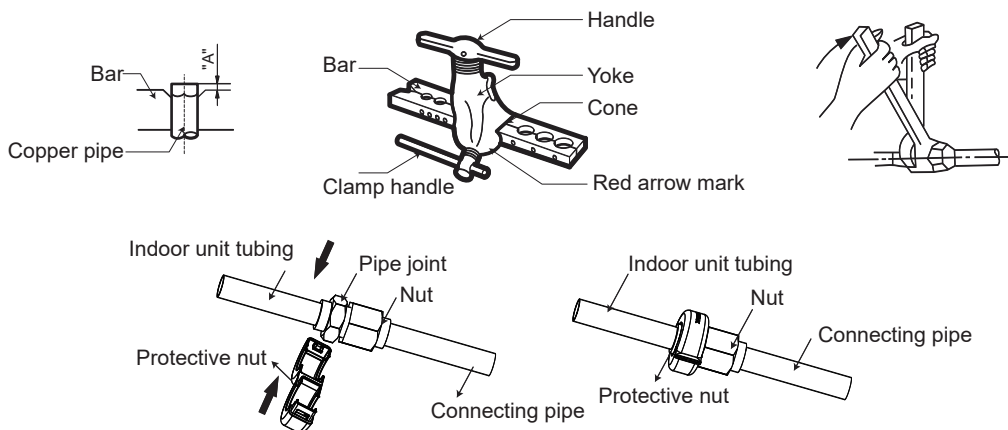

Outer diam.	Tightening torque(N·cm)	Additional tightening torque(N·cm)
φ6.35	1500 (153kgf·cm)	1600 (163kgf·cm)
φ9.52	2500 (255kgf·cm)	2600(265kgf·cm)
φ16	4500 (459kgf·cm)	4700 (479kgf·cm)

### CAUTION

Excessive torque can break nut on installation conditions.  
When flared joints are reused indoors,the flare part should be re-fabricated.

## 5.2 Installation precautions of Outdoor unit

### 5.2.1 Dimensions

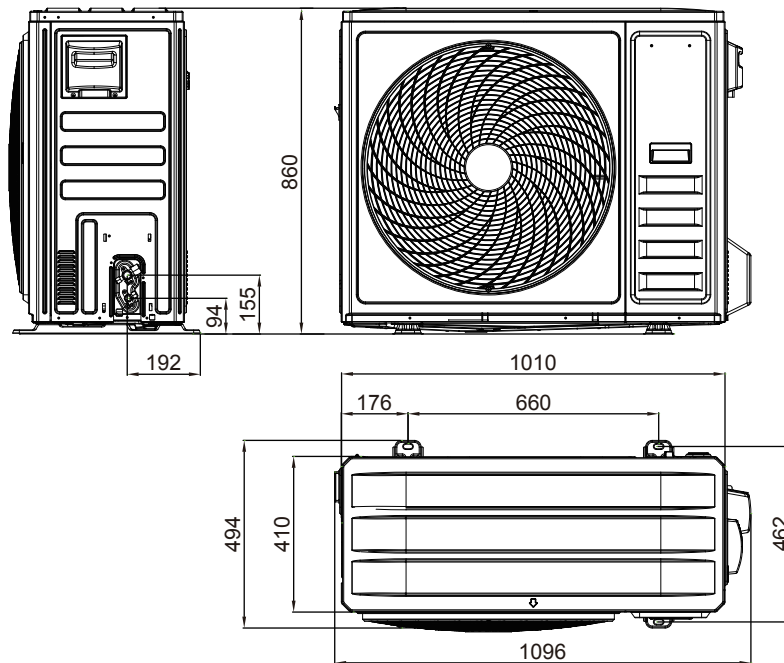

### 5.2.2 Installation requirements

- Check the strength and level of the installation ground so that the unit may not cause any vibrations or noise during the operation.
- In accordance with the foundation drawing in the figure, fix the unit securely by foundation bolts. (Prepare four sets each of  $\Phi 10$  Expansion bolts, nuts and washers which are readily available in the market.)
- Screw in the foundation bolts until their length is 20mm from the foundation surface.

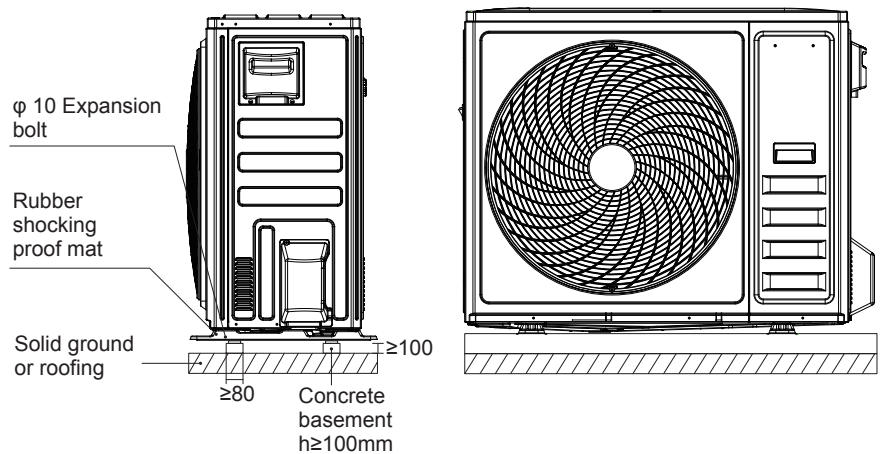

### 5.2.3 Drain hole position

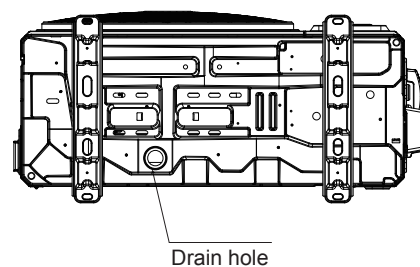

## ! CAUTION

It's necessary to install an electrical heating belt if water can't drain out in cold weather even the big drain hole has opened.  
It is suggested to site the unit with the base electric heater.

# 6 INSTALLATION OF OUTDOOR UNIT CONNECTING PIPES

## 6.1 Refrigerant piping

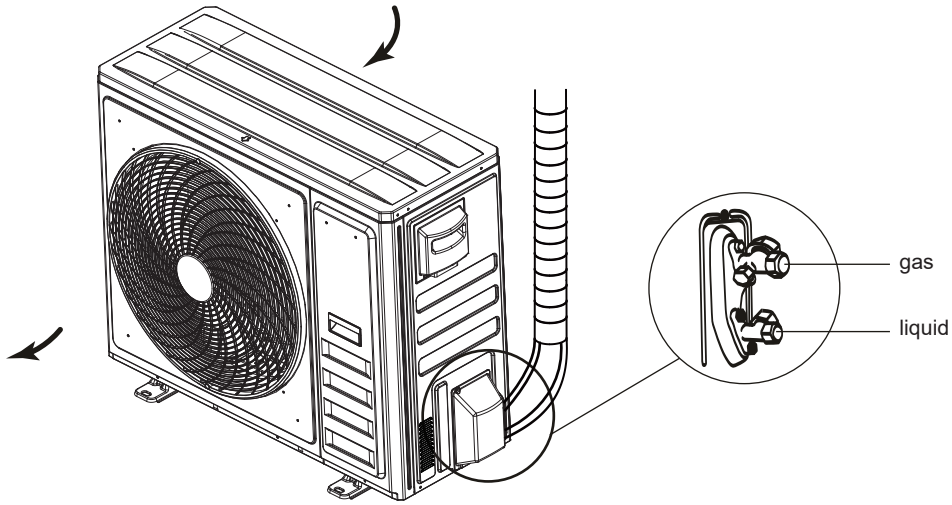

### ⚠ CAUTION

- Please pay attention to avoid the components where it is connecting to the connecting pipes.
- To prevent the refrigerant piping from oxidizing inside when welding, It's necessary to charge nitrogen, or oxide will chock the circulation system.

## 6.2 Leakage detection

Use soap water or leakage detector to check every joint whether leak or not.

Note:

A is high pressure side stop valve.

B is low pressure side stop valve.

C and D are connecting pipes interface of indoor and outdoor units

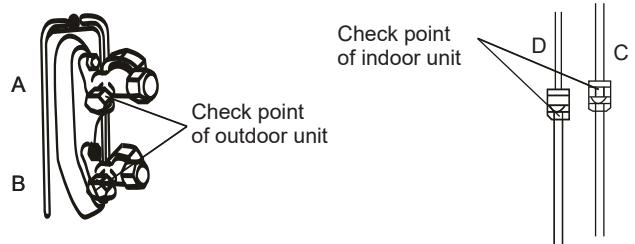

## 6.3 Heat insulation

In order to avoid the release of cold or heat from the connecting pipeline to the external environment during the operation of the equipment, please take effective insulation measures to separate the gas pipe and liquid pipe .

- 1) The gas side pipe should use closed cell foamed insulation material, which the fire-retardant is B1 grade and the heat resistance over 120°C.
- 2) When the external diameter of copper pipe  $\leq \phi 12.7\text{mm}$ , the thickness of the insulating layer at least more than 15mm; When the external diameter of copper pipe  $\geq \phi 15.9\text{mm}$ , the thickness of the insulating layer at least more than 20mm.
- 3) Please use attached heat-insulating materials do the heat insulation without clearance for the connecting parts of the indoor unit pipes.

### 6.4 Connecting method

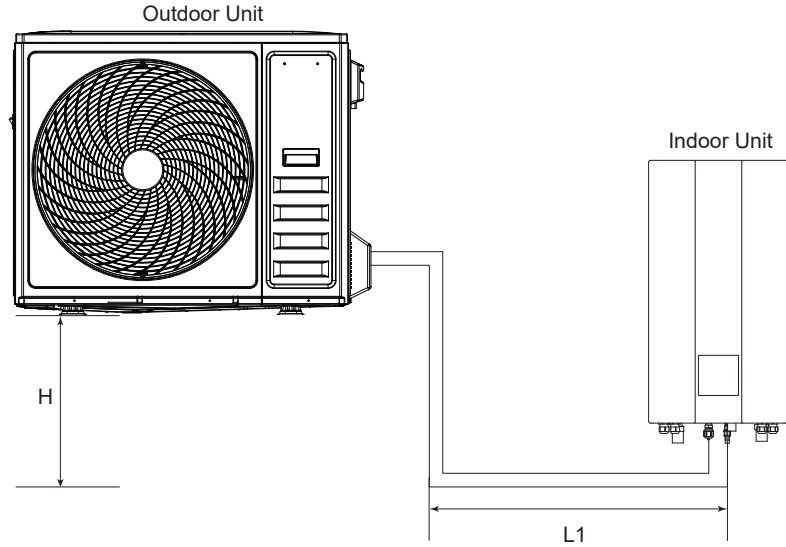

<b>Model</b>	12/14/16kW
<b>Max.piping length (H+L1)</b>	30m
<b>Max difference in height (H)</b>	20m

1) Size of pipes of Gas side and Liquid side

Model	Refrigerant	Gas side/Liquid side
12/14/16kW	R32	φ15.9/φ9.52

2) Connection method

	Gas side	Liquid side
12/14/16kW outdoor unit	Flaring	Flaring
Indoor unit	Flaring	Flaring

### 6.5 Remove dirt or water in the pipes

- 1) Make sure there is no any dirt or water before connecting the piping to the outdoor and indoor units.
- 2) Wash the pipes with high pressure nitrogen, never use refrigerant of outdoor unit.

### 6.6 Airtight testing

Charge pressured nitrogen after connecting indoor/outdoor unit pipes to do airtight testing.

#### **!** CAUTION

Pressured nitrogen [4.3MPa (44kg/cm<sup>2</sup>) for R32] should be used in the airtight testing.  
 Tighten high/low pressure valves before charging pressured nitrogen.  
 Charge pressure nitrogen from the connector on the pressure valves.  
 The airtight testing should never use any oxygen, flammable gas or poisonous gas.

### 6.7 Air purge with vacuum pump

- 1) Using vacuum pump to do the vacuum, never using refrigerant to expel the air.
- 2) Vacuuming should be done from liquid side.

### 6.8 Refrigerant amount to be added

Calculate the added refrigerant according to the diameter and the length of the liquid side pipe of the outdoor unit/indoor unit connection.  
 If the length of the liquid side pipe is less than 15 meters it is no need to add more refrigerant, so then calculating the added refrigerant the length of the liquid side pipe must subtract 15 meters.

Refrigerant to be added	Model	Total liquid pipe length L(m)	
		≤15m	> 15m
Total additional refrigerant	12/14/16 kW	0g	(L-15)×38g



# 7 OVERVIEW OF THE UNIT

## 7.1 Electronic control board

### 7.1.1 Main control board of indoor unit

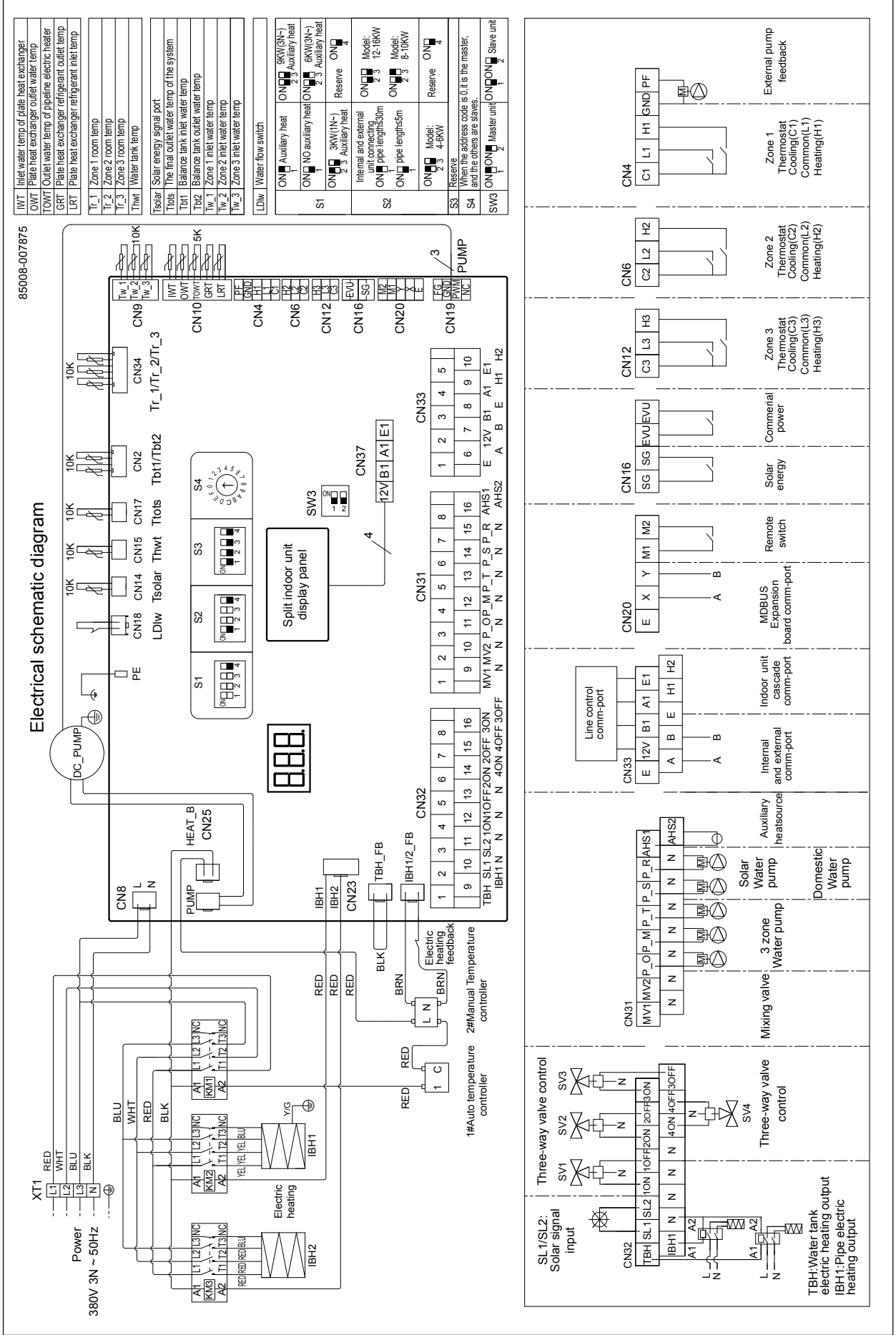

7.1.2 Main control board of outdoor unit

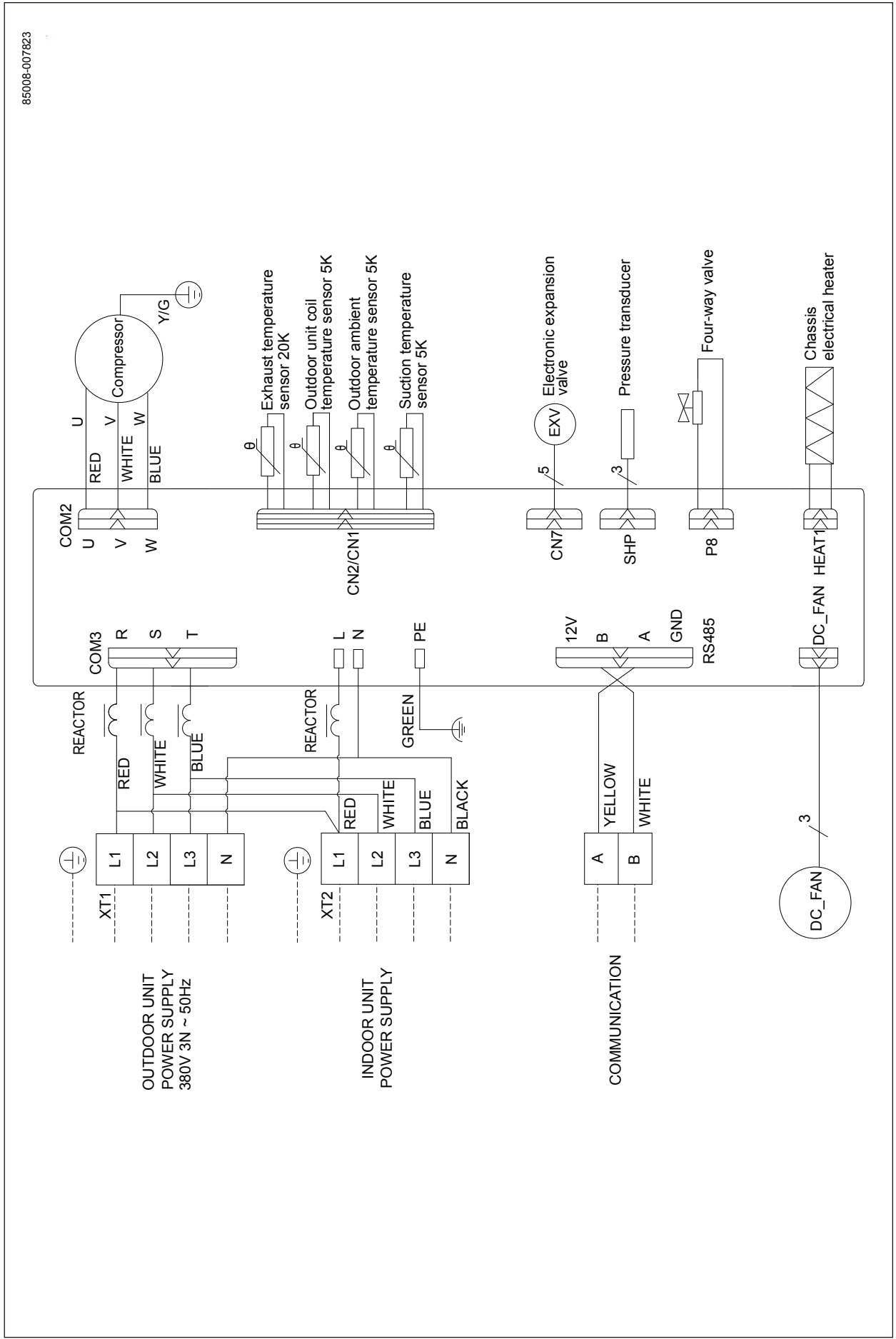

## 7.2 Filling water

- Connect the water supply to the filling valves and open the valve.
- Make sure all the automatic automatic bleed valve are opened (1.5-2 turns).
- Filling with water until the manometer indicates a pressure of approximately 2.0 bar. Remove air in the circuit as much as possible using the automatic air purge valves.

Do not fasten the black plastic cover on the automatic bleed valve at the topside of the unit when the system is running. Open the automatic bleed valve, turn it counterclockwise for 1.5-2 turns to release air from the system.

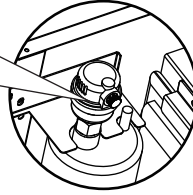

### ! NOTE

During filling, it might not be possible to remove all air in the system. Remaining air will be removed through the automatic bleed valve during the first operating hours of the system. Topping up the water afterwards might be required.

- The water pressure indicated on the manometer will vary depending on the water temperature (higher pressure at higher water temperature). However, at all times water pressure should remain above 0.3 bar to avoid air entering the circuit.
- The unit might drain-off too much water through the pressure relief valve.
- Water quality should be complied with EN 98/83 EC Directives.
- Detailed water quality condition can be found in EN 98/83 EC Directives.

## 7.3 Field wiring

### ! WARNING

A main switch or other means of disconnection, having a contact separation in all poles, must be incorporated in the fixed wiring in accordance with relevant local laws and regulations. Switch off the power supply before making any connections. Use only copper wires. Never squeeze bundled cables and make sure they do not come in contact with the piping and sharp edges. Make sure no external pressure is applied to the terminal connections. All field wirings and components must be installed by a licensed electrician and must comply with relevant local laws and regulations.

The field wiring must be carried out in accordance with the wiring diagram supplied with the unit and the instructions given below.

Be sure to use a dedicated power supply. Never use a power supply shared by another appliance.

Be sure to establish a ground. Do not ground the unit to a utility pipe, surge protector, or telephone ground. Incomplete grounding may cause electrical shock.

Be sure to install a ground fault circuit interrupter (30 mA). Failure to do it may cause electrical shock.

Be sure to install the required fuses or circuit breakers.

### 7.3.1 Precautions on electrical wiring work

- Fix cables so that cables do not make contact with the pipes (especially on the high pressure side).
- Secure the electrical wiring with cable ties as shown in figure so that it does not come in contact with the piping, particularly on the high-pressure side.
- Make sure no external pressure is applied to the terminal connectors.
- When installing the ground fault circuit interrupter make sure that it is compatible with the inverter (resistant to high frequency electrical noise) to avoid unnecessary opening of the ground fault circuit interrupter.

### 💡 NOTE

The ground fault circuit interrupter must be a high-speed type breaker of 30 mA (<0.1 s).

- This unit is equipped with an inverter. Installing a phase advancing capacitor not only will reduce the power factor improvement effect, but also may cause abnormal heating of the capacitor due to high-frequency waves. Never install a phase advancing capacitor as it could lead to an accident.

### 7.3.2 Wiring overview

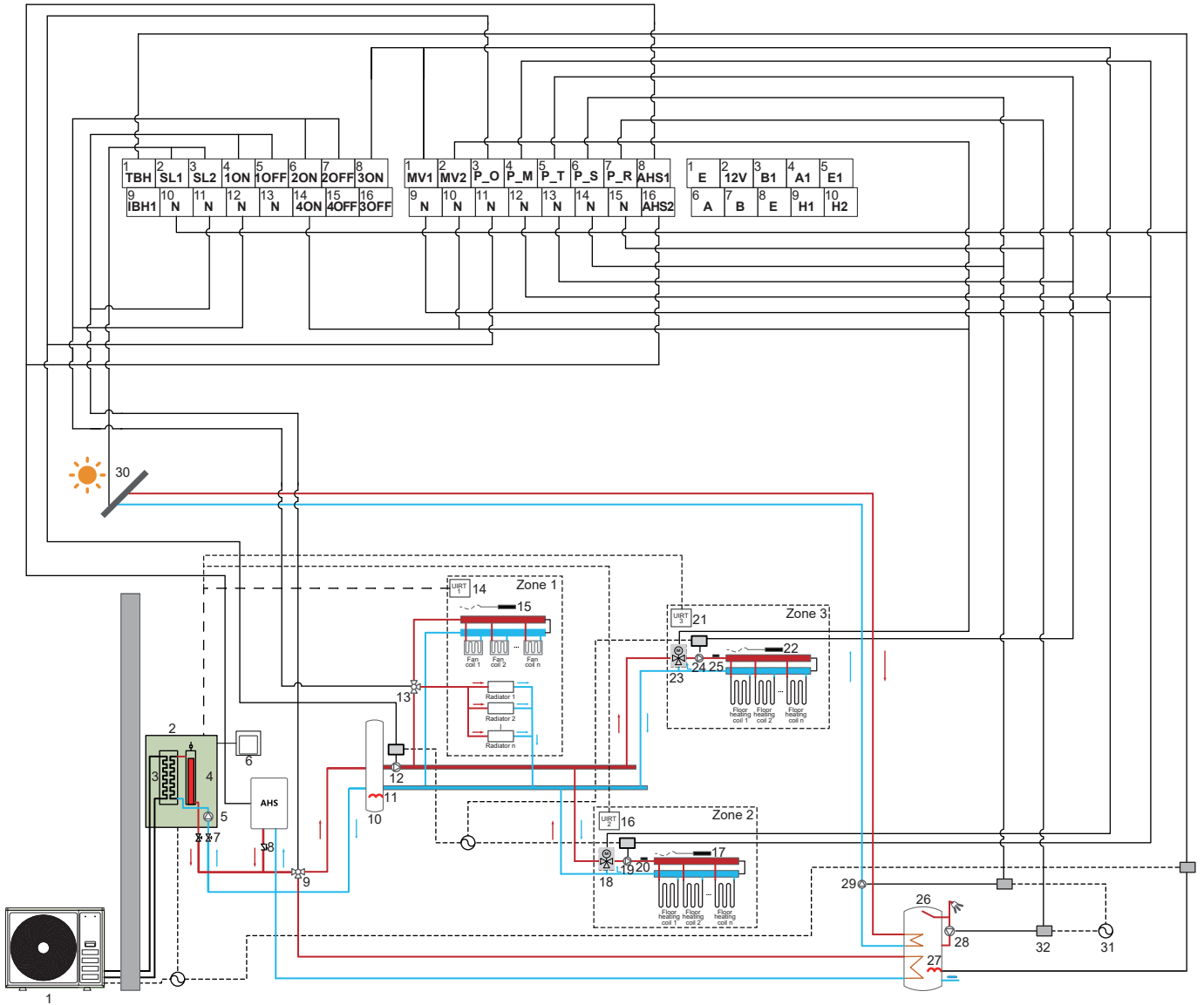

Code	Assembly unit	Code	Assembly unit
1	Outdoor unit	17	Zone 2 indoor temperature sensor (Tr-2)
2	Indoor unit	18	Zone 2 mixing valve
3	Plate heat exchanger	19	Zone 2 pump(P_M)
4	Backup electric heating	20	Zone 2 floor heating water inlet temperature sensor(Tw-2)
5	Internal circulator pump	21	Zone 3 room thermostat
6	Controller	22	Zone 3 indoor temperature sensor(Tr-3)
7	Stop valve	23	Zone 3 mixing valve
8	Check valve	24	Zone 3 pump(P_T)
9	3-way valve 1(SV1)	25	Zone 3 floor heating water inlet temperature sensor
10	Buffer tank	26	Domestic hot water tank
11	Buffer tank electric heater(IBH1)	27	Water tank electric heating(TBH)
12	Zone 1 pump(P_O)	28	Domestic hot water pump(P_R)
13	3-way valve 2(SV2)	29	Solar energy water pump(P_S)
14	Zone 1 room thermostat	30	Solar panels
15	Zone 1 indoor temperature sensor(Tr-1)	31	Power supply
16	Zone 2 room thermostat	32	Contactor

#### ! NOTE

- When using the mixing valve in Zone 3, the terminals connected are position 2(MV2), 14(4ON), 10(N).
- Zone 2: Setting the mixing valve (to the hot water direction 8(3ON), to the cold water direction 1(MV1); Zone 3: Setting the mixing valve, 14(4ON) is for the hot water direction, 2(MV2) is to the cold water direction.
- Code 7-32 are field supply.

Wiring requirements				
Item	Description	Current	Required number of conductors	Maximum running current
1	Solar energy kit signal cable	AC	2	200mA
2	User interface cable	AC	5	200mA
3	Room thermostat cable	AC	2	200mA(1)
4	Solar pump control cable	AC	2	200mA(1)
5	Outside circulation pump control cable	AC	2	200mA(1)
6	DHW pump control cable	AC	2	200mA(1)
7	SV2: 3-way valve control cable	AC	3	200mA(1)
8	SV1: 3-way valve control cable	AC	3	200mA(1)
9	Booster heater control cable	AC	2	200mA(1)
10	Power supply cable for indoor unit	AC	4+GND 16(6kW heater)	8.9A
			4+GND 16(9kW heater)	13.3A

(1) Minimum cable section AWG18 (0.75mm<sup>2</sup>).

If the current of the load is large, an AC contactor is needed.

### NOTE

Please use H07RN-F for the power wire, all the cables are connect to high voltage except for thermistor cable and cable for user interface.

Equipment must be grounded.

- All high-voltage external load, if it is metal or a grounded port, must be grounded.
- All external load current is needed less than 0.2A, if the single load current is more than 0.2A, the load must be controlled through AC contactor.
- "AHS1" "AHS2", "H" "C" etc, wiring terminal ports provide only the switch signal.
- Please refer to image of 7.3.6 to get the ports position in the unit.
- Plate heat exchanger E-Heating tape and Flow switch E-Heating tape share a control port.

Field wiring guidelines

- Most field wiring on the unit is to be made on the terminal block inside the switch box. To gain access to the terminal block, remove the switch box service panel.

### WARNING

Switch off all power including the unit power supply and backup heater and domestic hot water tank power supply (if applicable) before removing the switch box service panel.

- Fix all cables using cable ties.
- A dedicated power circuit is required for the backup heater.
- Installations equipped with a domestic hot water tank (field supply) require a dedicated power circuit for the booster heater.
- Please refer to the domestic hot water tank Installation & Owner's Manual.
- Lay out the electrical wiring so that the front cover will not rise up when doing wiring work and attach the front cover securely.
- Follow the electric wiring diagram for electrical wiring works (the electric wiring diagrams are located on the rear side of door 2).
- Install the wires and fix the cover firmly so that the cover may be fit in properly.

### 7.3.3 Precautions on wiring of power supply

- Use a round crimp-style terminal for connection to the power supply terminal board. In case it cannot be used due to unavoidable reasons, be sure to observe the following instructions.
- Do not connect different gauge wires to the same power supply terminal. (Loose connections may cause overheating.)
- When connecting wires of the same gauge, connect them according to the figure below.

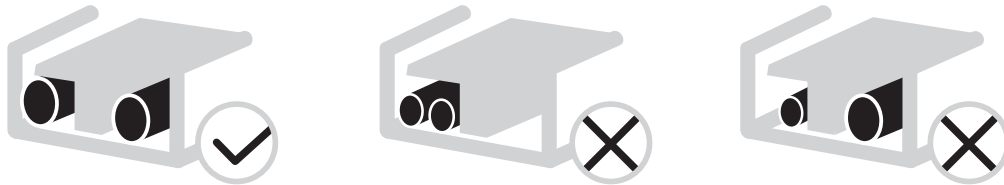

- Use the correct screwdriver to tighten the terminal screws. Small screwdrivers can damage the screw head and prevent appropriate tightening.
- Over-tightening the terminal screws may damage the screws.
- Attach a ground fault circuit interrupter and fuse to the power supply line.
- When wiring, make certain that prescribed wires are used, carry out complete connections, and fix the wires so that outside force cannot affect the terminals.

### 7.3.4 Safety device requirement

1. Select the wire diameters( minimum value) individually for each unit based on the table 1 and table 2, where the rated current in table 1 means MCA in table 2. In case the MCA exceeds 63A, the wire diameters should be selected according to the national wiring regulation.
2. Select circuit breaker that having a contact separation in all poles not less than 3 mm providing full disconnection, where MFA is used to select the current circuit breakers and residual current operation breakers:

Table 1

Rated current of appliance: (A)	Nominal cross-sectional area (mm <sup>2</sup> )	
	Flexible cords	Cable for fixed wiring
≤3	0.5 and 0.75	1 and 2.5
>3 and ≤6	0.75 and 1	1 and 2.5
>6 and ≤10	1 and 1.5	1 and 2.5
>10 and ≤16	1.5 and 2.5	1.5 and 4
>16 and ≤25	2.5 and 4	2.5 and 6
>25 and ≤32	4 and 6	4 and 10
>32 and ≤50	6 and 10	6 and 16
>50 and ≤63	10 and 16	10 and 25

Table 2

System	Power Current							Compressor		OFM		IWPM	
	Voltage (V)	Hz	Min. (V)	Max. (V)	MCA (A)	TOCA (A)	MFA (A)	MSC (A)	RLA (A)	KW	FLA (A)	KW	FLA (A)
12kW 3-PH	380-415	50	342	456	10	14	16	-	9.15	0.17	1.50	0.087	0.66
14kW 3-PH	380-415	50	342	456	11	14	16	-	10.15	0.17	1.50	0.087	0.66
16kW 3-PH	380-415	50	342	456	12	14	16	-	11.15	0.17	1.50	0.087	0.66

#### NOTE

**MCA** : Max. Circuit Amps. (A)

**TOCA**: Total Over-current Amps. (A)

**MFA**: Max. Fuse Amps. (A)

**MSC**: Max. Starting Amps. (A)

**RLA**: In nominal cooling or heating test condition, the input Amps of compressor where MAX. Hz can operate Rated Load Amps. (A)

**OFM**:Outdoor fan motor

**IWPM**:Indoor Water Pump Motor

**KW**: Rated Motor Output

**FLA**: Full Load Amps. (A)

### 7.3.5 Specifications of standard wiring components

#### 1) Equipment main Power Supply Wiring of indoor unit

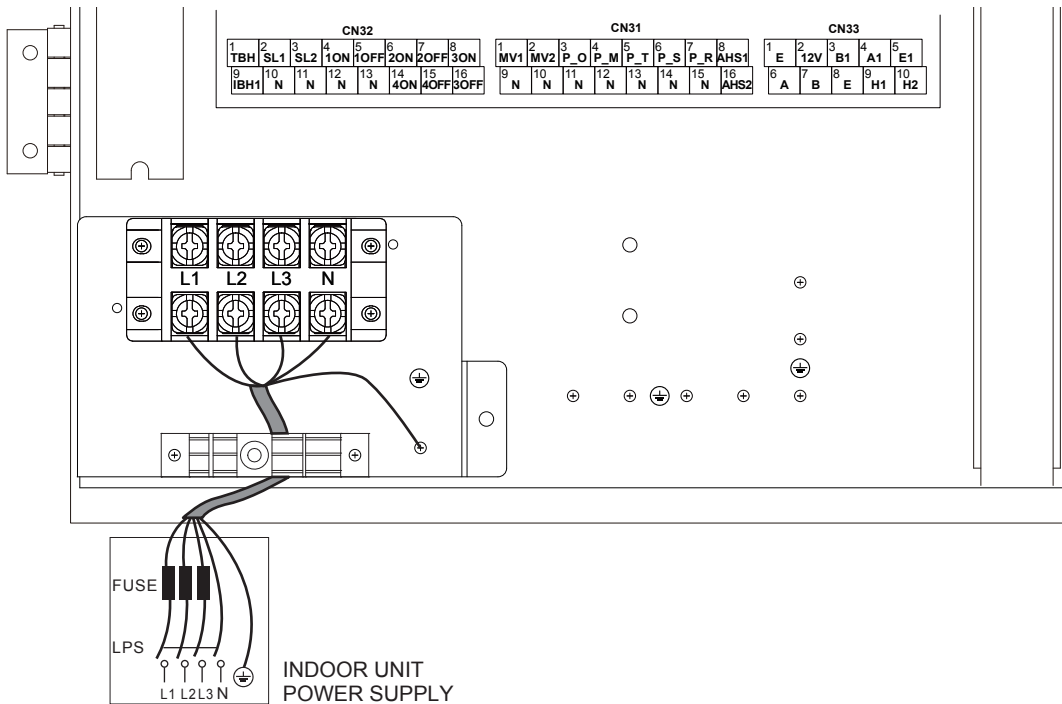

- Stated values are maximum values (see electrical data for exact values).

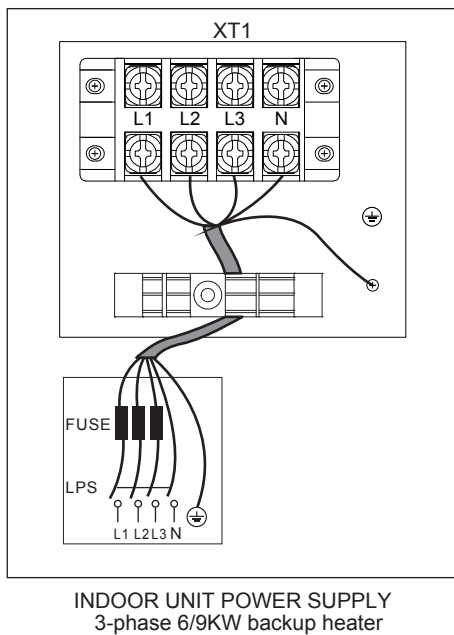

Unit	3-phase 6/9KW backup heater
Wiring size(mm <sup>2</sup> )	2.5

- Stated values are maximum values (see electrical data for exact values).

#### **!** CAUTION

When connecting to the power supply terminal, use the circular wiring terminal with the insulation casing. Use power cord that conforms to the specifications and connect the power cord firmly. To prevent the cord from being pulled out by external force, make sure it is fixed securely.

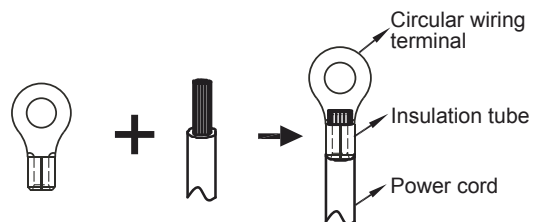

#### **!** NOTE

The ground fault circuit interrupter must be a high-speed type breaker of 30 mA (<0.1 s). Flexible cord must meet 60245IE (H05VV-F) standards.

## 2) Remove the switch box cover of Outdoor unit

Unit	12kW	14kW	16kW
Maximum overcurrent protector(MOP)(A)	40	40	40
Wiring size(mm <sup>2</sup> )	6.0	6.0	6.0

- Stated values are maximum values (see electrical data for exact values).

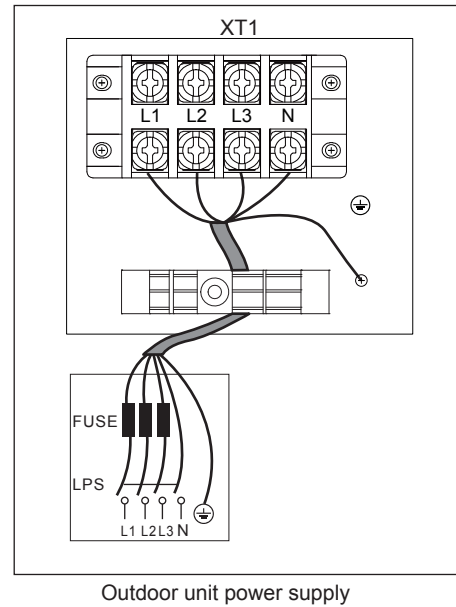

## 7.3.6 Connection for other components of Indoor unit

### Indoor Unit

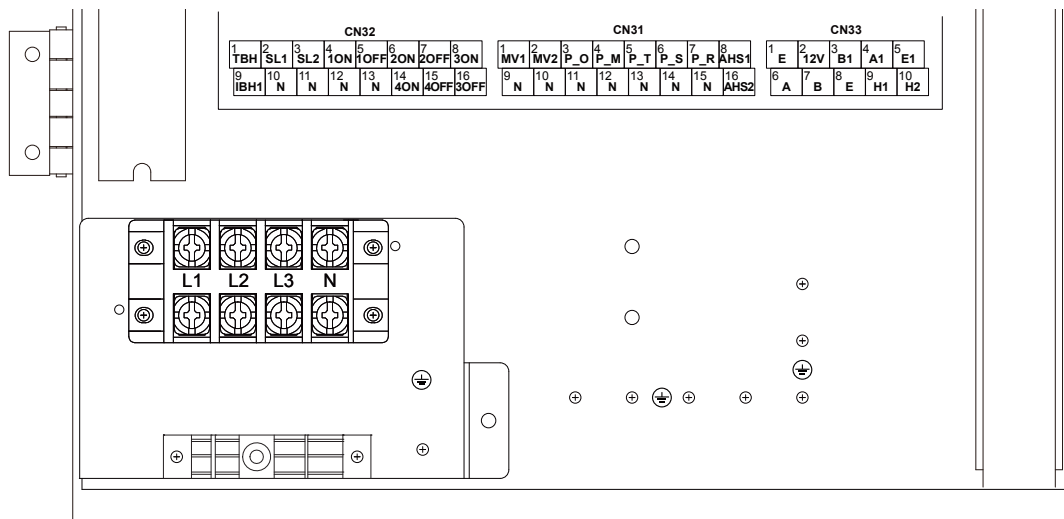

Print	Connect to	Print	Connect to	Print	Connect to	
TBH	Water tank electric heating	4OFF	3-way valve 4	A	Internal and external comm-port	
N		4ON		B		
IBH1	Backup electric heating	N	Mixing valve	E		
N		MV1		12V		
SL1	Solar energy signal port	MV2	Zone 1 pump	B1	Wire controller comm-port	
SL2		N		A1		
1OFF	3-way valve 1	P_O	Zone 2 pump	E1		Indoor unit cascade comm-port
1ON		N		H1		
N		P_M	H2			
2OFF	3-way valve 2	N	Zone 3 pump	E		
2ON		P_T				
N		N				
3OFF	3-way valve 3	P_S	Solar energy water pump	XT1	L1	Indoor unit power supplier
3ON		N			L2	
N		P_R	L3			
		N	N			



Type:Port provide the signal with 220V voltage. If the current of load is <math><0.2A</math>, load can connect to the port directly.

If the current of load is 0.2A, the AC contactor is required to be connected for the load.

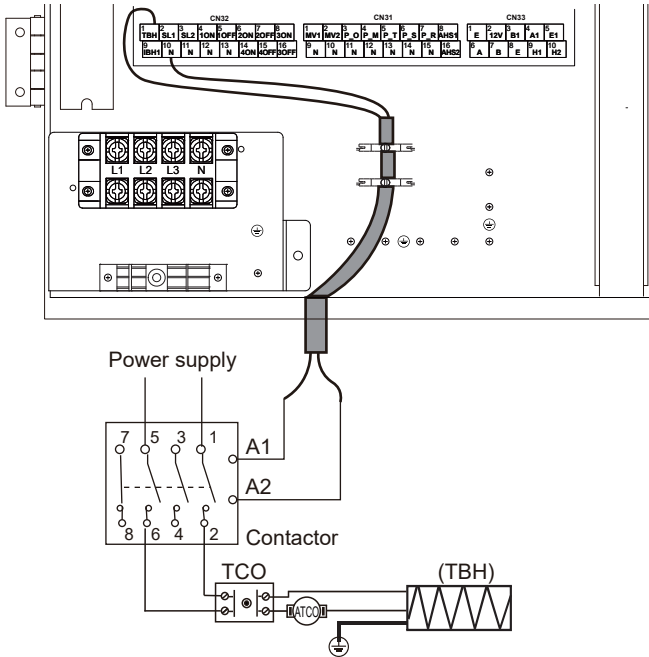

Control signal port of indoor unit: The TBH contains terminals for solar energy, 3-way valve, pump, water tank electric heating, etc.

The parts wiring is illustrated below:

### 1) For Solar energy signal port

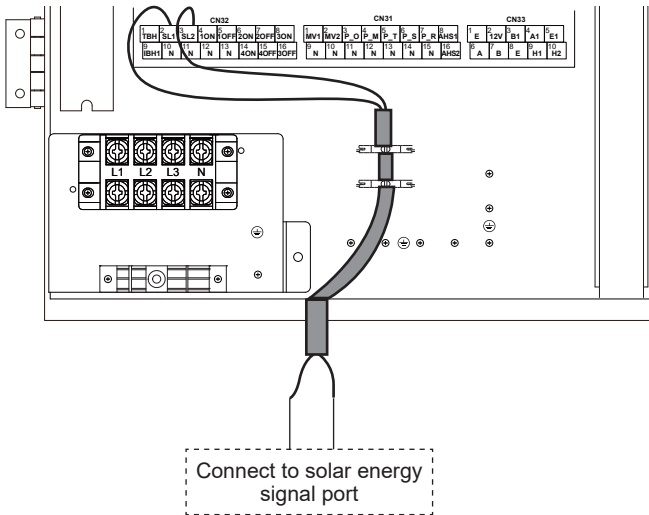

### 2) For 3-way valve

#### • 3-way valve 1(SV1)

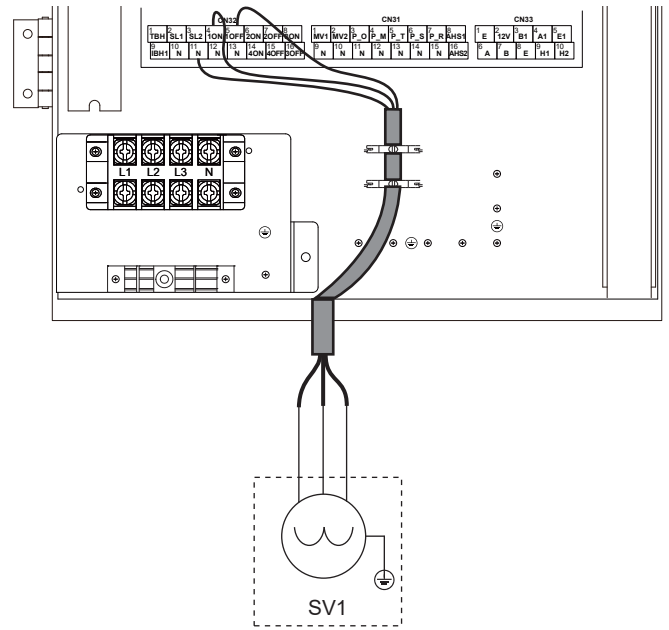

#### • 3-way valve 2(SV2)

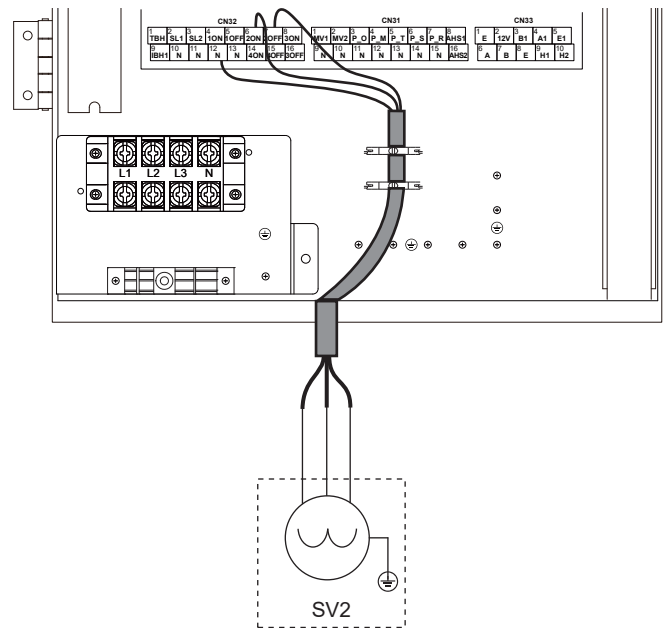

• 3-way value 3(SV3)

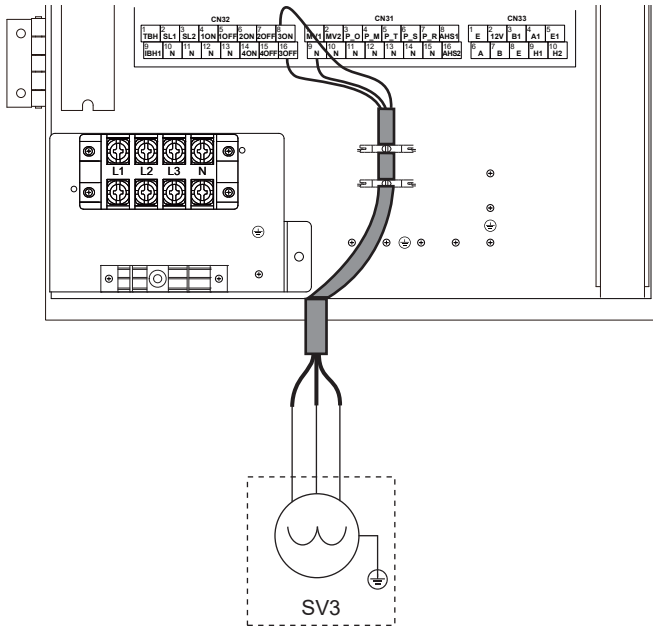

• 3-way value 4(SV4)

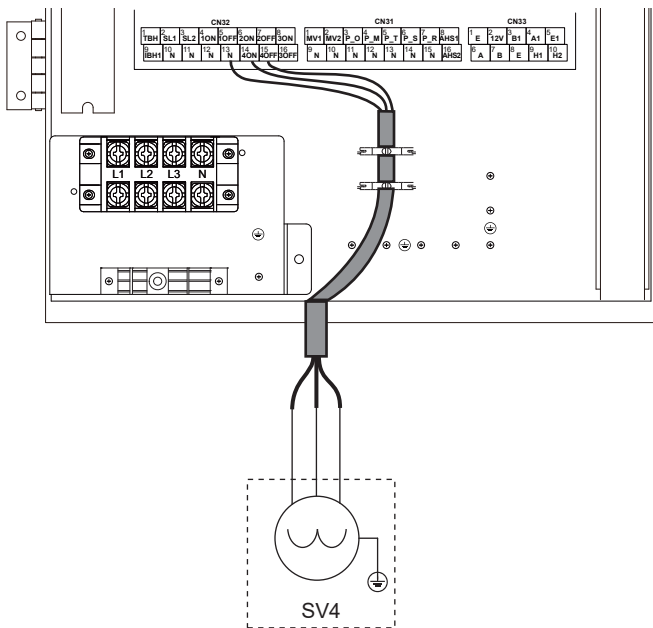

a) Procedure

- Connect the cable to the appropriate terminals as shown in the picture.
- Fix the cable reliably.

3) For zone 1 pump(P\_O)

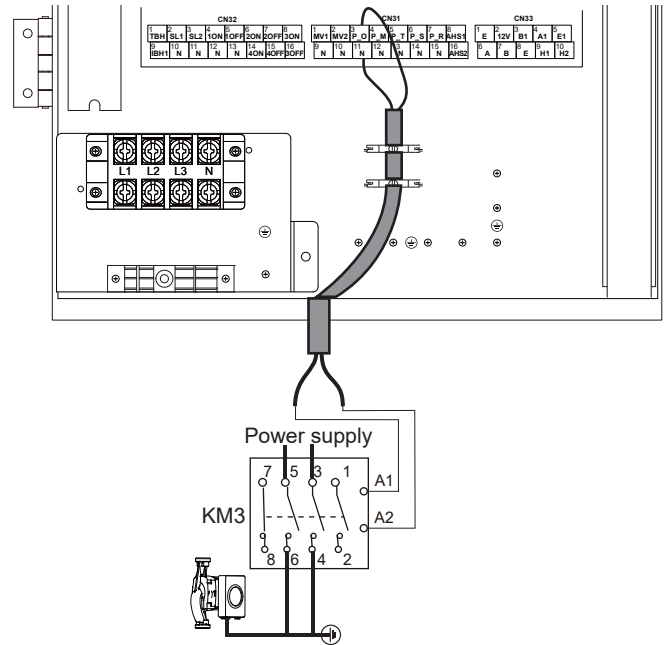

a) Procedure

- Connect the cable to the appropriate terminals as shown in the picture.
- Fix the cable reliably.

4) For zone 2 pump(P\_M)

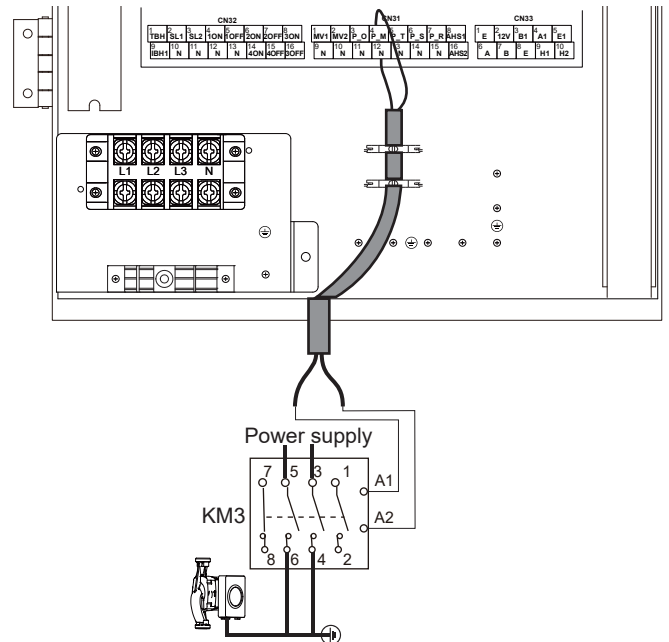

a) Procedure

- Connect the cable to the appropriate terminals as shown in the picture.
- Fix the cable reliably.

### 5) For zone 3 pump(P\_T)

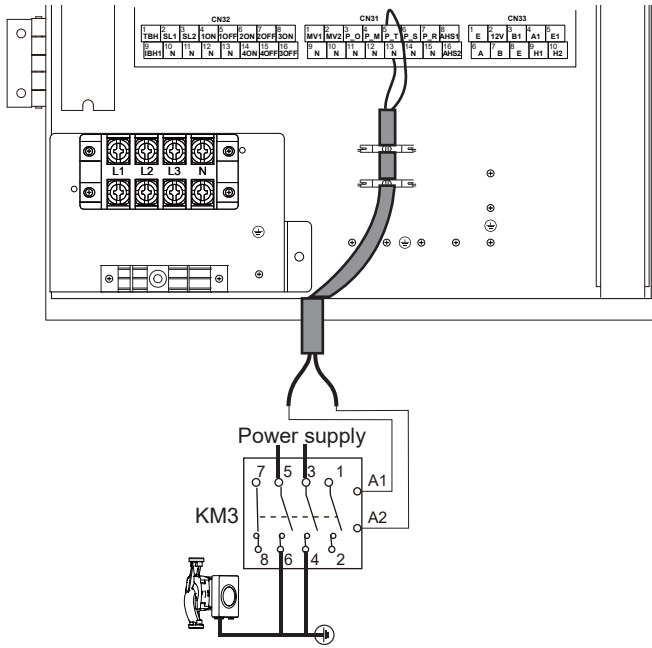

#### a) Procedure

- Connect the cable to the appropriate terminals as shown in the picture.
- Fix the cable reliably.

### 6) For domestic hot water pump(P\_R)

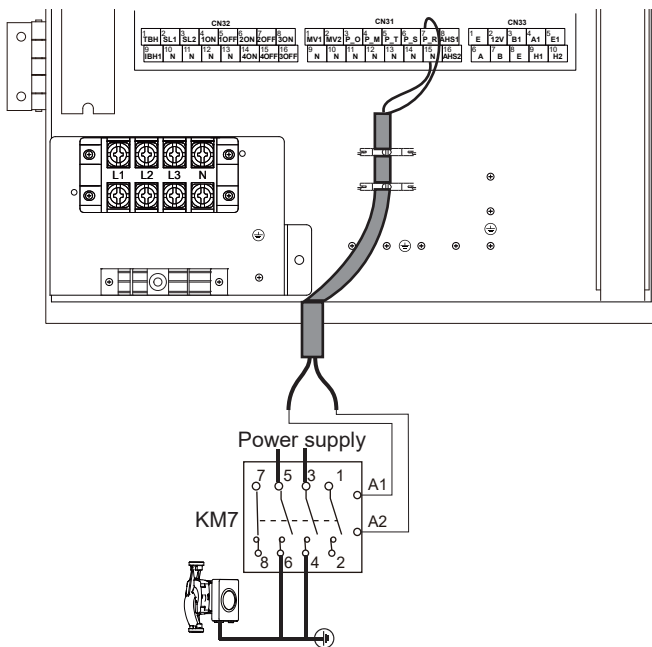

#### a) Procedure

- Connect the cable to the appropriate terminals as shown in the picture.
- Fix the cable reliably.

### 7) For room thermostat(Low voltage)

"POWER IN" provide the working voltage to the RT.

#### • Zone 1

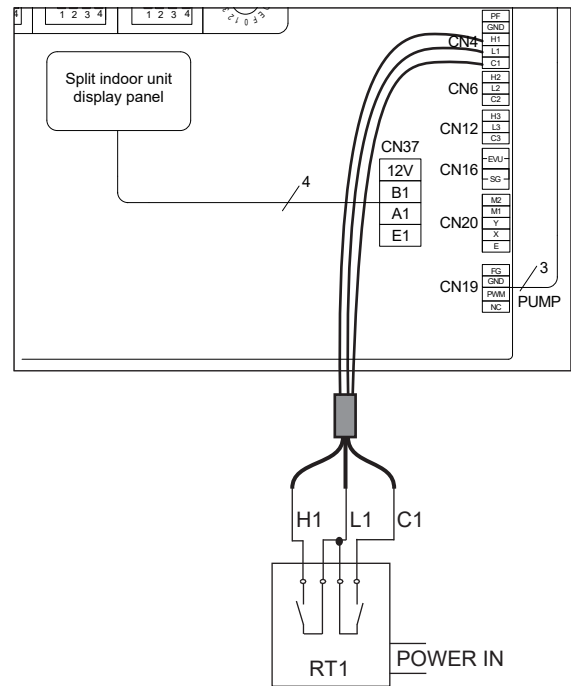

#### • Zone 2

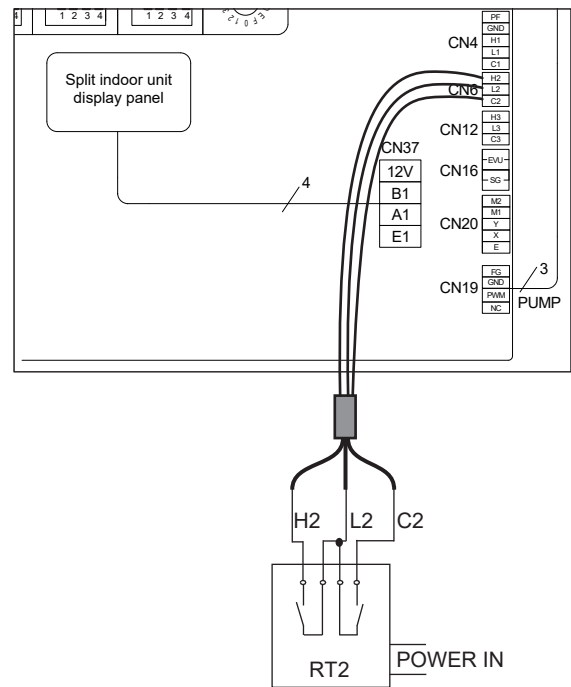

• Zone 3

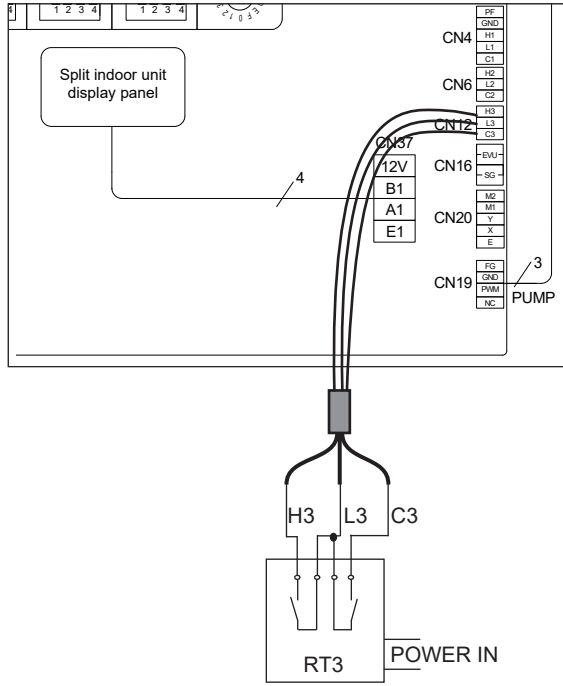

There are three zones for connecting the thermostat cable (as described in the picture above) and it depends on the application.

8) For water tank electric heating

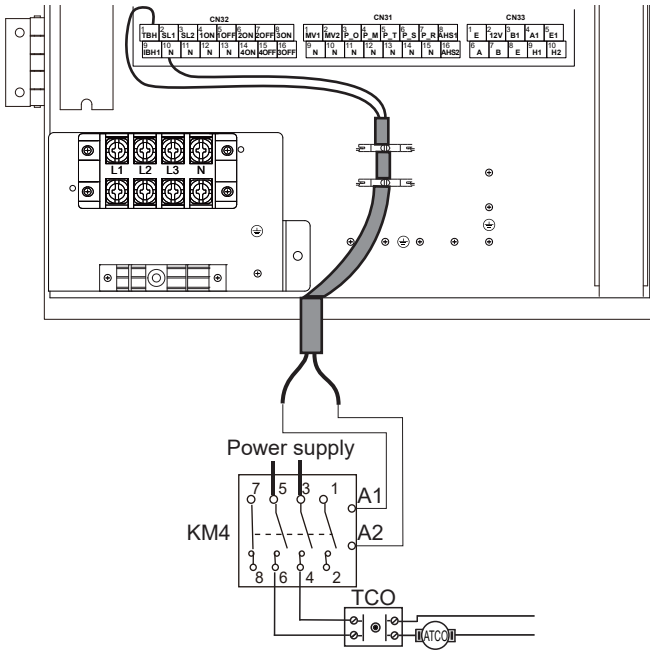

**! WARNING**  
The unit only sends an ON/OFF signal to the heater.

9) For auxiliary heat source control

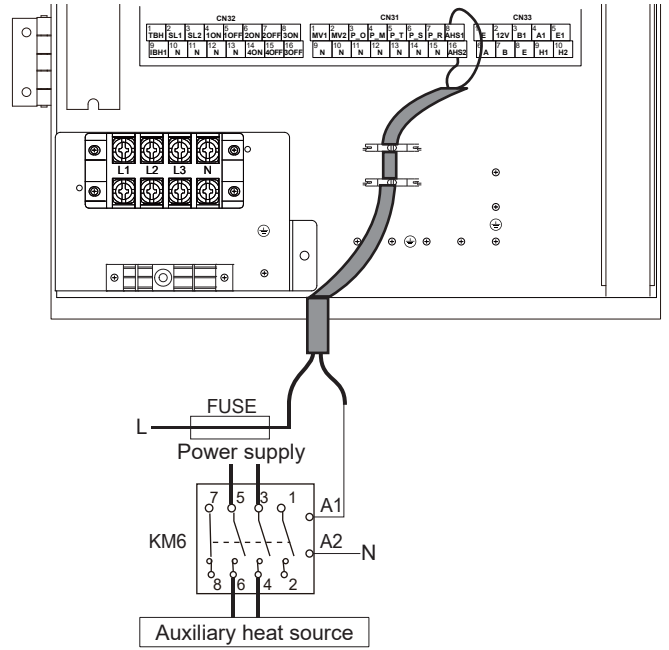

**! WARNING**  
This part only applies to Basic. For Customized, because there is an interval backup heater in the unit, the indoor unit should not be connected to any auxiliary heat source.

10) For backup electric heating

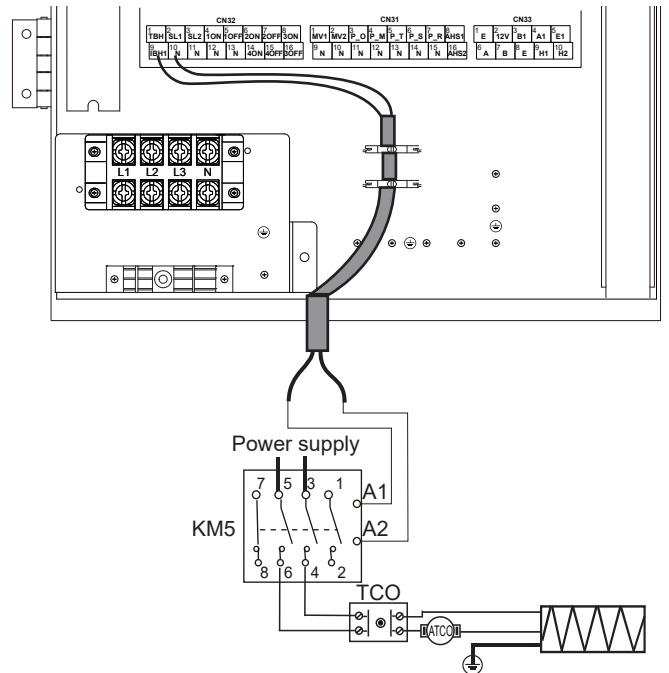

For standard indoor unit 16kW, there is no internal backup heater inside the indoor unit, but the indoor unit can be connected to an external backup heater, as described in the picture below.

## 11) For smart grid

The unit has smart grid function, there are two ports on PCB to connect SG signal and EVU signal as following:

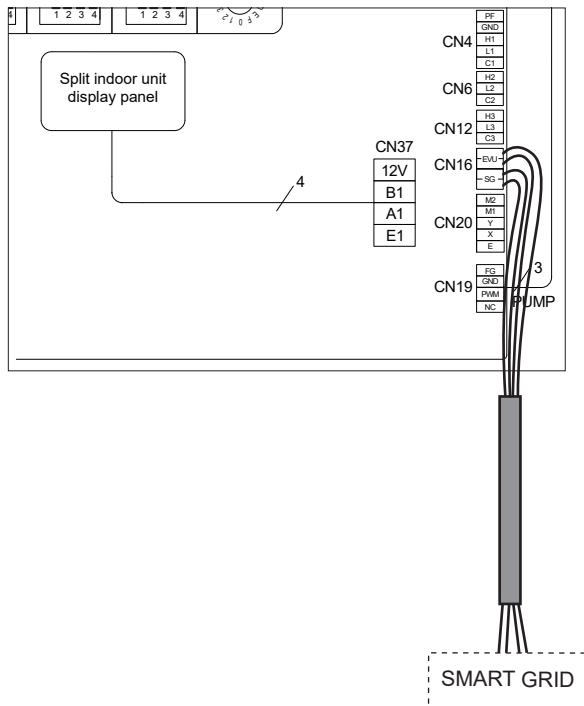

1. When EVU signal is on , and SG signal is on, as long as the DHW mode is set to be valid, heat pump will operate DHW mode priority and the DHW mode setting temperature will be change to 70°C. Thwt<69°C, the TBH is on,Thwt≥70°C, the TBH is off.
2. When EVU signal is on , and SG signal is off, as long as the DHW mode is set to be valid and the mode is on, heat pump will operate DHW mode priority. Thwt<Thwt(Set)-2, the TBH is on,Thwt≥Thwt(Set)+3, the TBH is off.
3. When EVU signal is off, and SG signal is on, the unit operates normally.
4. When both EVU and SG signal are off, the unit operates as below: The unit will not operate DHW mode, and the TBH is invalid, disinfect function is invalid. The max running time for cooling/heating is "SG RUNNING TIME", then unit will be off.

## 8 TEST RUN AND FINAL CHECKS

The installer is obliged to verify correct operation of unit after installation.

### 8.1 Final checks

Before switching on the unit, read following recommendations:

- When the complete installation and all necessary settings have been carried out, close all front panels of the unit and refit the unit cover.
- The service panel of the switch box may only be opened by a licensed electrician for maintenance purposes.

#### NOTE

During the first running period of the unit, required power input may be higher than stated on the nameplate of the unit. This phenomenon originates from the compressor that needs elapse of a 50 hours run in period before reaching smooth operation and stable power consumption.

### 8.2 Test run operation (manually)

If required, the installer can perform a manual test run operation at any time to check correct operation of air purge, heating, cooling and domestic water heating, refer to " MENU > PARAMETERS CONFIG > 2.SYSTEM PARAMETERS > PASSWORD 2345 > 1.USER PARAMETERS SETTING > 9.TEST SETTING " in wired controller.

## 9 PRECAUTIONS ON REFRIGERANT LEAKAGE

When the refrigerant charge in appliance is more than 1.842kg, following requirement should be complied with.

- Requirement for charge limits in unventilated areas:

The maximum refrigerant charge in appliance shall be in accordance with the following:

$$m_{\max} = 2.5 \times (\text{LFL})^{5/4} \times 1.8 \times (A)^{1/2}$$

or the required minimum floor area  $A_{\min}$  to install an appliance with refrigerant charge  $m_c$  shall be in accordance with following:

$$A_{\min} = (m_c / (2.5 \times (\text{LFL})^{5/4} \times 1.8))^2$$

where

$m_{\max}$  is the allowable maximum charge in a room, in kg.

A is the room area, in  $m^2$ .

$A_{\min}$  is the required minimum room area, in  $m^2$ .

$m_c$  is the refrigerant charge in appliance, in kg.

LFL is the lower flammable limit in  $kg/m^3$ , the value is 0.306 for R32 refrigerant.

- Install mechanical ventilator to reduce the refrigerant thickness, under critical level. (ventilate regularly).
- Install leak alarm facility related to mechanical ventilator if you can not regularly ventilate.

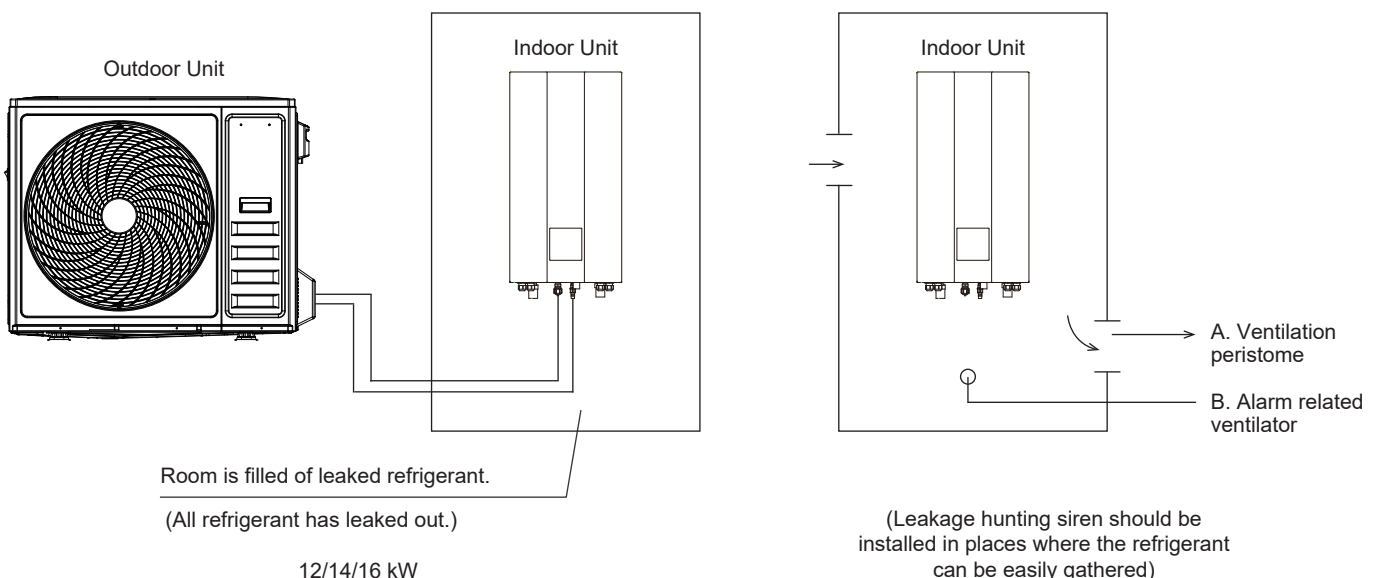

# 10 MAINTENANCE AND SERVICE

---

In order to ensure optimal availability of the unit, a number of checks and inspections on the unit and the field wiring have to be carried out at regular intervals.

This maintenance needs to be carried out by your local technician.

In order to ensure optimal availability of the unit, a number of checks and inspections on the unit and the field wiring have to be carried out at regular intervals.

This maintenance has to be carried out by your local technician.

## DANGER

### ELECTRIC SHOCK

- Before carrying out any maintenance or repairing activity, must switch off the power supply on the supply panel.
- Do not touch any live part for 10 minutes after the power supply is turned off.
- The crank heater of compressor may operate even in standby.
- Please note that some sections of the electric component box are hot.
- Forbid touching any conductive parts.
- Forbid rinsing the unit. It may cause electric shock or fire.
- Forbid leaving the unit unattended when service panel is removed.

The following checks must be performed at least once a year by qualified person.

- Water pressure  
Check the water pressure, if it is below 1 bar, fill water to the system.
- Water filter  
Clean the water filter.
- Water pressure relief valve  
Check for correct operation of the pressure relief valve by turning the black knob on the valve counter-clockwise:  
-If you do not hear a clacking sound, contact your local dealer.  
-In case the water keeps running out of the unit, close both the water inlet and outlet shut-off valves first and then contact your local dealer.
- Pressure relief valve hose  
Check that the pressure relief valve hose is positioned appropriately to drain the water.
- Backup heater vessel insulation cover  
Check that the backup heater insulation cover is fastened tightly around the backup heater vessel.
- Domestic hot water tank pressure relief valve (field supply) Applies only to installations with a domestic hot water tank. Check for correct operation of the pressure relief valve on the domestic hot water tank.

# 11 TURN OVER TO CUSTOMER

The owner's manual of indoor unit and owner's manual of outdoor unit must be turned over to the customer. Explain the contents in the owner's manual to the customers in details.

## WARNING

- **Ask your dealer for installation of the heat pump.**  
Incomplete installation performed by yourself may result in a water leakage, electric shock, and fire.
- **Ask your dealer for improvement, repair, and maintenance.**  
Incomplete improvement, repair, and maintenance may result in a water leakage, electric shock, and fire.
- **In order to avoid electric shock, fire or injury, or if you detect any abnormality such as smell of fire, turn off the power supply and call your dealer for instructions.**
- **Never let the indoor unit or the remote controller get wet.**  
It may cause an electric shock or a fire.
- **Never press the button of the remote controller with a hard, pointed object.**  
The remote controller may be damaged.
- **Never replace a fuse with that of wrong rated current or other wires when a fuse blows out.**  
Use of wire or copper wire may cause the unit to break down or cause a fire.
- **It is not good for your health to expose your body to the air flow for a long time.**
- **Do not insert fingers, rods or other objects into the air inlet or outlet.**  
When the fan is rotating at high speed, it will cause injury.
- **Never use a flammable spray such as hair spray, lacquer or paint near the unit.**  
It may cause a fire.
- **Never put any objects into the air inlet or outlet.**  
Objects touching the fan at high speed can be dangerous.
- **Do not dispose this product as unsorted municipal waste. Collection of such waste separately for special treatment is necessary.**  
Do not dispose of electrical appliances as unsorted municipal waste, use separate collection facilities. Contact your local government for information regarding the connection systems available.
- **If electrical appliances are disposed of in landfills or dumps, hazardous substances can leak into the ground water and get into the food chain, damaging your health and well-being.**
- **To prevent refrigerant leak, contact your dealer.**  
When the system is installed and runs in a small room, it is required to keep the concentration of the refrigerant, if by any chance coming out, below the limit. Otherwise, oxygen in the room may be affected, resulting in a serious accident.
- **The refrigerant in the heat pump is safe and normally does not leak.**  
If the refrigerant leaks in the room, contact with a fire of a burner, a heater or a cooker may result in a harmful gas.
- **Turn off any combustible heating devices, ventilate the room, and contact the dealer where you purchased the unit.**  
Do not use the heat pump until a service person confirms that the portion where the refrigerant leaks is repaired.

## CAUTION

- **Do not use the heat pump for other purposes.**  
In order to avoid any quality deterioration, do not use the unit for cooling precision instruments, food, plants, animals or works of art.
- **Before cleaning, be sure to stop the operation, turn the breaker off or pull out the supply cord.**  
Otherwise, an electric shock and injury may result.
- **In order to avoid electric shock or fire, make sure that an earth leak detector is installed.**  
Be sure the heat pump is grounded.  
In order to avoid electric shock, make sure that the unit is grounded and that the earth wire is not connected to gas or water pipe, lightning conductor or telephone earth wire.
- **In order to avoid injury, do not remove the fan guard of the outdoor unit.**
- **Do not operate the heat pump with a wet hand.**  
An electric shock may happen.
- **Do not touch the heat exchanger fins.**  
These fins are sharp and could result in cutting injuries.
- **Do not place items which might be damaged by moisture under the indoor unit.**  
Condensation may form if the humidity is above 80%, the drain outlet is blocked or the filter is polluted.
- **After a long use, check the unit stand and fitting for damage.**  
If damaged, the unit may fall and result in injury.
- **To avoid oxygen deficiency, ventilate the room sufficiently if equipment with burner is used together with the heat pump.**
- **Arrange the drain hose to ensure smooth drainage.**  
Incomplete drainage may cause wetting of the building, furniture etc.
- **Never touch the internal parts of the controller.**  
Do not remove the front panel. Some parts inside are dangerous to touch, and a machine trouble may happen.
- **Never do the maintenances work by yourself.**  
Please contact your local dealer to do the maintenances work.
- **Never expose little children, plants or animals directly to the air flow.**  
Adverse influence to little children, animals and plants may occur.
- **Do not allow a child to mount on the outdoor unit or avoid placing any object on it.**  
Falling or tumbling may result in injury.
- **Do not operate the heat pump when using a room fumigation - type insecticide.**  
Failure to observe could cause the chemicals to become deposited in the unit, which could endanger the health of those who are hypersensitive to chemicals.
- **Do not place appliances which produce open fire in places exposed to the air flow from the unit or under the indoor unit.**  
It may cause incomplete combustion or deformation of the unit due to the heat.



## CAUTION

- **Do not install the heat pump at any place where flammable gas may leak out.**

If the gas leaks out and stays around the heat pump, a fire may break out.

- **The appliance is not intended for use by young children or infirm persons without supervision.**

Young children should be supervised to ensure that they do not play with the appliance.

- **The outdoor unit window-shades should be periodic cleaning in case of being jammed.**

This window-shapes is heat dissipation outlet of components, if being jammed will cause the components shorten their service life spans because of overheated for a long time.

- **The temperature of refrigerant circuit will be high, please keep the interconnection cable away from the copper tube.**

## 12.3 Heating capacity

- The heating operation is a heat-pump process that heat will be absorbed from outdoor air and released to indoor water. Once the outdoor temperature is decreased, heating capacity decreased correspondingly.
- Other heating equipment is suggested to be used together when outdoor temperature is too low.
- In some extreme cold upland that buy the indoor unit equipped with electrical heater will obtain better performance.( Refer to indoor unit owner's manual for details)

## NOTE

- 1) The motor in outdoor Unit will continue running for 60 seconds for to remove residual heat when the outdoor Unit receiving OFF command during heating operation.
- 2) If the heat pump malfunction occurs because of disturb, please reconnect the heat pump to power, then turn on it again.

# 12 OPERATION AND PERFORMANCE

## 12.1 Protection Equipment

This Protection Equipment will enable the Heat Pump to stop when the Heat Pump is to be directed running compulsively.

The protection equipment may be activated in following conditions:

### Cooling Operation

- The air inlet or air outlet of outdoor unit is blocked.
- Strong wind is Continuously blowing to the air outlet of the outdoor unit.

### Heating Operation

- Too much rubbish adhere to the filter in the water system.
- The air outlet of indoor unit is choked.
- Mishandling in operation:

If mishandling happens because of lighting or mobile wireless, please shut off the manual power switch, and turn on again, then push the ON/OFF button.

## NOTE

When the protection equipment starts, please shut down the manual power switch, and restart operation after problem is solved.

## 12.2 About power cut

If power is cut during operation, stop all the operation immediately in case of power comes again. If the auto-restart function is set on, then the unit will auto-restart.

## 12.4 Compressor protection feature

A protection feature prevents the heat pump from being activated for approximately several minutes when it restarts immediately after operation.

## 12.5 Cooling and heating operation

The the indoor unit in the same system can not run cooling and heating at the same time.

If the Heat Pump Administrator has set running mode, then the heat pump can not run on modes other than the presetted. Standby or No Priority will be displayed in the Control Panel.

## 12.6 Features of heating operation

Water will not become hot immediately at the beginning of the heating operation, 3~5 minutes ago (depends on the indoor and outdoor temperature), until the indoor heat exchanger become hot, then becomes hot.

During operation, the fan motor in the outdoor unit may stop running under high temperature.

## 12.7 Defrost in the heating operation

During heating operation, outdoor unit sometimes will frost. To increase efficiency, the unit will start defrosting automatically (about 2~10 minutes), and then water will be drained out from outdoor unit.

During defrosting, the fan motors in the outdoor unit will stop running.

# 13 ERROR CODES

When a safety device is activated, an error code will be displayed on the user interface. A list of all errors and corrective actions can be found in the table below.

Reset the safety by turning the unit OFF and back ON.

In case this procedure for resetting the safety is not successful, contact your local dealer.

Err code	Malfunction or protection	The exclusion method
d1	Abnormal outlet water temperature after auxiliary heating	<ol style="list-style-type: none"> <li>1. Check the resistance of the sensor.</li> <li>2. The sensor connector is loosen. Reconnect it.</li> <li>3. The sensor connector is wet or there is water in. remove the water, make the connector dry. Add waterproof adhesive</li> <li>4. The sensor failure, change a new sensor.</li> </ol>
d2	Abnormal temperature of plate heat exchange inlet water	<ol style="list-style-type: none"> <li>1. Check the resistance of the sensor.</li> <li>2. The sensor connector is loosen. Reconnect it.</li> <li>3. The sensor connector is wet or there is water in. Remove the water, make the connector dry. Add waterproof adhesive.</li> <li>4. The sensor failure, change a new sensor.</li> </ol>
d3	Abnormal temperature of plate heat exchange outlet water	<ol style="list-style-type: none"> <li>1. Check the resistance of the sensor.</li> <li>2. The sensor connector is loosen. Reconnect it.</li> <li>3. The sensor connector is wet or there is water in. Remove the water, make the connector dry. Add waterproof adhesive</li> <li>4. The sensor failure, change a new sensor.</li> </ol>
d4	Plate heat exchanger refrigerant gas pipe is abnormal	<ol style="list-style-type: none"> <li>1. Check the resistance of the sensor.</li> <li>2. The sensor connector is loosen. Reconnect it.</li> <li>3. The sensor connector is wet or there is water in. remove the water, make the connector dry. Add waterproof adhesive</li> <li>4. The sensor failure, change a new sensor.</li> </ol>
d5	Plate heat exchanger refrigerant liquid pipe is abnormal	<ol style="list-style-type: none"> <li>1. Check the resistance of the sensor.</li> <li>2. The sensor connector is loosen. Reconnect it.</li> <li>3. The sensor connector is wet or there is water in. Remove the water, make the connector dry. Add waterproof adhesive.</li> <li>4. The sensor failure, change a new sensor.</li> </ol>
d6	Abnormal final outlet water temperature of the system	<ol style="list-style-type: none"> <li>1. Check the resistance of the sensor.</li> <li>2. The sensor is in the interface.</li> <li>3. The sensor failure, change a new sensor or change a new interface.</li> </ol>
d7	Zone 1 inlet water temperature Tw1 fault	<ol style="list-style-type: none"> <li>1. Check the resistance of the sensor.</li> <li>2. The sensor is in the interface.</li> <li>3. The sensor failure, change a new sensor or change a new interface.</li> </ol>
d8	Zone 2 inlet water temperature Tw2 fault	<ol style="list-style-type: none"> <li>1. Check the resistance of the sensor.</li> <li>2. The sensor is in the interface.</li> <li>3. The sensor failure, change a new sensor or change a new interface.</li> </ol>
d9	Zone 3 inlet water temperature Tw3 fault	<ol style="list-style-type: none"> <li>1. Check the resistance of the sensor.</li> <li>2. The sensor is in the interface.</li> <li>3. The sensor failure, change a new sensor or change a new interface.</li> </ol>
dA	Zone 1 Room Temperature Tr1 fault	<ol style="list-style-type: none"> <li>1. Check the resistance of the sensor.</li> <li>2. The sensor is in the interface.</li> <li>3. The sensor failure, change a new sensor or change a new interface.</li> </ol>
dB	Zone 2 Room Temperature Tr2 fault	<ol style="list-style-type: none"> <li>1. Check the resistance of the sensor.</li> <li>2. The sensor is in the interface.</li> <li>3. The sensor failure, change a new sensor or change a new interface.</li> </ol>
dC	Zone 3 Room Temperature Tr3 fault	<ol style="list-style-type: none"> <li>1. Check the resistance of the sensor.</li> <li>2. The sensor connector is loosen. Reconnect it.</li> <li>3. The sensor connector is wet or there is water in. remove the water, make the connector dry. Add waterproof adhesive.</li> <li>4. The sensor failure, change a new sensor.</li> </ol>

Err code	Malfunction or protection	The exclusion method
dF	Balance tank inlet water temperature Tbt1 fault	<ol style="list-style-type: none"> <li>1. Check the resistance of the sensor.</li> <li>2. The sensor connector is loosen. Reconnect it.</li> <li>3. The sensor connector is wet or there is water in. remove the water, make the connector dry. Add waterproof adhesive.</li> <li>4. The sensor failure, change a new sensor.</li> </ol>
dH	Balance tank outlet water temperature Tbt2 fault	<ol style="list-style-type: none"> <li>1. Check the resistance of the sensor.</li> <li>2. The sensor connector is loosen. Reconnect it.</li> <li>3. The sensor connector is wet or there is water in. remove the water, make the connector dry. Add waterproof adhesive.</li> <li>4. The sensor failure, change a new sensor.</li> </ol>
dj	Solar Temperature Tsolar fault	<ol style="list-style-type: none"> <li>1. Check the resistance of the sensor.</li> <li>2. The sensor connector is loosen. Reconnect it.</li> <li>3. The sensor connector is wet or there is water in. remove the water, make the connector dry. Add waterproof adhesive.</li> <li>4. The sensor failure, change a new sensor.</li> </ol>
dn	Hot water tank temperature Thwt fault	<ol style="list-style-type: none"> <li>1. Check the resistance of the sensor.</li> <li>2. The sensor connector is loosen. Reconnect it.</li> <li>3. The sensor connector is wet or there is water in. remove the water, make the connector dry. Add waterproof adhesive.</li> <li>4. The sensor failure, change a new sensor.</li> <li>5. If you want to close the domestic water heating when sensor do not connected to the system, then sensor can not be detected, refer to 4.4 Domestic hot water setting.</li> </ol>
L1	The water temperature difference between plate heat exchanger inlet and outlet is too large	<ol style="list-style-type: none"> <li>1. Check that all shut off valves of the water circuit are completely open.</li> <li>2. Check if the water filter needs cleaning.</li> <li>3. Connect the water supply to the filling valves and open the valve. Filling with some water until the manometer indicates a pressure of approximately 2.0 bar.</li> <li>4. Make sure there is no air in the system (purge air).</li> <li>5. Check on the manometer that there is sufficient water pressure. The water pressure must be &gt;1 bar(water is cold).</li> <li>6. Check that the pump speed setting is on the highest speed.</li> <li>7. Make sure that the expansion vessel is not broken.</li> <li>8. Check that the resistance in the water circuit is not too high for the pump.</li> </ol>
L2	The water temperature difference between plate heat exchanger inlet and outlet is abnormal	<ol style="list-style-type: none"> <li>1. Check that all shut off valves of the water circuit are completely open.</li> <li>2. Check if the water filter needs cleaning.</li> <li>3. Connect the water supply to the filling valves and open the valve. Filling with some water until the manometer indicates a pressure of approximately 2.0 bar.</li> <li>4. Make sure there is no air in the system (purge air).</li> <li>5. Check on the manometer that there is sufficient water pressure. The water pressure must be &gt;1 bar(water is cold).</li> <li>6. Check that the pump speed setting is on the highest speed.</li> <li>7. Make sure that the expansion vessel is not broken.</li> <li>8. Check that the resistance in the water circuit is not too high for the pump.</li> </ol>
L3	Plate heat exchanger outlet water temperature is too low	<ol style="list-style-type: none"> <li>1. Check the resistance of temperature sensor.</li> <li>2. The sensor connector is loosen. Reconnect it.</li> <li>3. The sensor failure, change a new sensor.</li> <li>4. Check that all shut off valves of the water circuit are completely open.</li> <li>5. Check if the water filter needs cleaning.</li> <li>6. Insufficient water flow.</li> <li>7. Detect the amount of refrigerant.</li> </ol>
L4	Plate heat exchanger outlet water temperature is too high	<ol style="list-style-type: none"> <li>1. Check the resistance of temperature sensor.</li> <li>2. The sensor connector is loosen. Reconnect it.</li> <li>3. The sensor failure, change a new sensor.</li> <li>4. Check that all shut off valves of the water circuit are completely open.</li> <li>5. Check if the water filter needs cleaning.</li> <li>6. Insufficient water flow.</li> <li>7. Detect the amount of refrigerant.</li> </ol>
L5	Plate heat exchanger inlet water temperature is too low	<ol style="list-style-type: none"> <li>1. Check the inlet water temperature.</li> <li>2. Check the resistance of temperature sensor.</li> <li>3. The sensor connector is loosen. Reconnect it.</li> <li>4. The sensor failure, change a new sensor.</li> </ol>
L6	Plate heat exchanger inlet water temperature is too high	<ol style="list-style-type: none"> <li>1. Check the inlet water temperature</li> <li>2. Check the resistance of temperature sensor</li> <li>3. The sensor connector is loosen. Reconnect it</li> <li>4. The sensor failure, change a new sensor.</li> </ol>
L7	Water side system antifreeze	<ol style="list-style-type: none"> <li>1. Check the resistance of the two sensor .</li> <li>2. Check the two sensors locations .</li> <li>3. The water sensor is loosen. Reconnect it.</li> <li>4. The water sensor is broken, change a new sensor.</li> <li>5. Four-way valve is blocked. Restart the unit again to let the valve change the direction.</li> <li>6. Four-way valve is broken, change a new valve.</li> </ol>

Err code	Malfunction or protection	The exclusion method
L8	Insufficient water flow	<ol style="list-style-type: none"> <li>1. Check whether the water flow switch is installed loosely.</li> <li>2. Check that all shut off valves of the water circuit are completely open.</li> <li>3. Check if the water filter needs cleaning.</li> <li>4. Connect the water supply to the filling valves and open the valve. Filling with some water until the manometer indicates a pressure of approximately 2.0 bar.</li> <li>5. Make sure there is no air in the system (purge air).</li> <li>6. Check on the manometer that there is sufficient water pressure. The water pressure must be &gt;1 bar(water is cold).</li> <li>7. Check that the pump speed setting is on the highest speed.</li> <li>8. Make sure that the expansion vessel is not broken.</li> <li>9. Check that the resistance in the water circuit is not too high for the pump.</li> <li>10. If this error occurs at defrost operation (during space heating or domestic water heating), make sure that the backup heater power supply is wired correctly and that fuses are not blown.</li> <li>11. Check that the pump fuse and PCB fuse are not blown.</li> </ol>
Lb	Abnormal auxiliary electric heating feedback	<ol style="list-style-type: none"> <li>1. Interface wiring disconnected.</li> <li>2. There is no water in the water tank when the auxiliary electric heating is started.</li> <li>3. Check whether the temperature Controller is reset, it can be reset manually.</li> </ol>
LC	Abnormal water tank electric heat feedback	<ol style="list-style-type: none"> <li>1. Interface wiring disconnected</li> <li>2. There is no water in the water tank when the electric heating is started</li> </ol>
Ld	Frequent emergency defrost	<ol style="list-style-type: none"> <li>1. Detect the amount of refrigerant</li> </ol>
LE	External water pump fault	<ol style="list-style-type: none"> <li>1. Poor connection of water pump wiring.</li> <li>2. The water pump is failure,change a new water pump</li> </ol>
LP	Main water pump fault	<ol style="list-style-type: none"> <li>1. Poor connection of water pump wiring.</li> <li>2. The water pump is failure,change a new water pump</li> </ol>

Err code	Malfunction or protection	The exclusion method
E0	Communication error between indoor unit and outdoor unit	1. Check whether the communication wire is properly connected and in good contact. 2. Whether there is a high magnetic field or high power interfere, such as lifts, large power transformers, etc.. To add a barrier to protect the unit or to move the unit to the other place.
E3	Outdoor unit coil temperature sensor fault T3	
E4	System maintenance data fault	
E5	The model setting is abnormal	1. Check whether the temperature sensor is normal
E7	Outdoor ambient temperature sensor failure T4	1. Check whether the temperature sensor is normal.
E8	Outdoor exhaust temperature sensor failure TP	1. Check whether the temperature sensor is normal.
EA	Outdoor current sensor failure	
Eb	Indoor unit and wired	1.Check the wire controller connection cable 2.Replace the wire controller
EC	Communication failure between drive board and main PCB	1. Check whether the power supply of the outdoor unit is correct; 2. Check whether the communication line between outdoor units is connected correctly 3. Check whether the control board of the outdoor unit is powered; 4. If the fault cannot be solved,please contact us!
Ed	Indoor unit EEPROM fault	1.Initialize all parameters. 2.main control board of indoor unit is broken, change a new PCB. If the fault still cannot be solved after initialization, please contact us!
EE	Outdoor EEPROM failure	1.Initialize all parameters. 2.main control board of outdoor unit is broken, change a new PCB. If the fault still cannot be solved after initialization, please contact us!
EF	Outdoor DC fan failure	1. Strong wind or typhoon below toward to the fan, to make the fan running in the opposite direction. Change the unit direction or make shelter to avoid typhoon below to the fan. 2.Check whether the PWM fan wiring is normal 3. Fan motor is broken, change a new fan motor.
EH	Malfunction of outdoor air intake sensor	1. The sensor failure, change a new sensor.
Ej	Thermostat communication fault	
En	Module communication fault	1.Check the wiring method of cascade function. 2.Check the dialing code of cascade address.
F2	Exhaust temperature sensor failure protection	1. Check the resistance of the sensor 2. The sensor connector is loosen. Reconnect it. 3. The sensor connector is wet or there is water in. remove the water, make the connector dry. Add waterproof adhesive 4. The sensor failure, change a new sensor.
F3	Outer tube temperature sensor failure protection	Check whether the temperature sensor is normal.
F5	PFC protection	1. Check fan, air duct and ambient temperature 2. Extend acceleration time 3. Check compressor model and model parameters 4. Check the input voltage 5. Please power off for a few minutes, then power on again and start again. 6. Check whether the PFC inductor lead wire or inductor coil is short-circuited, or seek service 7. Check mechanical system, compressor refrigerant, etc., or seek service
F6	Compressor loss/reverse phase protection	1. Check the installation wiring 2. Check the input voltage 3. Adjust parameters to eliminate oscillation
F7	Module temperature protection	1. Power off and then power on and try again, if the problem still exists, please seek service
F8	Abnormal commutation of four-way valve	1. Whether the wiring of the four-way valve is correct; 2. Whether the power supply voltage of the outdoor unit is too low, resulting in abnormal reversing of the 4-way valve 3. If the fault still cannot be solved, consult the manufacturer

Err code	Malfunction or protection	The exclusion method
FA	Compressor phase current detection failure	1. Power off and then power on and try again, if the problem still exists, please seek service
Fy	Fluorine deficiency protection	1. Check whether the unit leaks refrigerant. If there is leakage, the leak point needs to be repaired.
H1	High pressure switch protection	Check whether compressor high pressure switch is normal. Heating mode, DHW mode: 1. The water flow is low; water temp is high, whether there is air in the water system. Release the air. 2. Water pressure is lower than 0.1Mpa, charge the water to let the pressure in the range of 0.15~0.2Mpa. 3. Over charge the refrigerant volume. Recharge the refrigerant in right volume. 4. Electrical expansion valve locked or winding connector is loosen. Tap-tap the valve body and plug in/ plug off the connector for several times to make sure the valve is working correctly. And install the winding in the right location DHW mode: Water tank heat exchanger is smaller . Cooling mode: 1.The finned heat exchanger cover is not removed. Remove it. 2.The finned heat exchanger is dirty or something is block on the surface. Clean the heat exchanger or remove the obstruction.
H2	Low pressure switch protection	1. Check whether compressor low pressure switch is normal. 2. Lack of refrigerant. Charge the refrigerant in right volume. 3.When at heating mode or DHW mode, the finned heat exchanger is dirty or something is block on the surface. Clean the finned heat exchanger or remove the obstruction. 4. The water flow is too low in cooling mode.increase the water flow. 5. Electrical expansion valve locked or winding connector is loosen. Tap-tap the valve body and plug in/ plug off the connector for several times to make sure the valve is working correctly.
H3	High pressure sensor failure	1. Check whether the sensor is connected properly. 2. Pressure sensor failure,change a new sensor.
P0	IPM module protection	
P1	Dc bus overvoltage, undervoltage AC input undervoltage	1. Check input power supply,wiring. 2. Check input voltage. 3. Check and replace.
P2	Ac input overcurrent	
P4	Outdoor exhaust temperature protection	1. Check the resistance of the sensor. 2. The sensor connector is loosen. Reconnect it. 3. The sensor connector is wet or there is water in. remove the water, make the connector dry. Add waterproof adhesive. 4. The sensor failure, change a new sensor. 5. Check for lack of refrigerant.
P5	Refrigeration antifreeze Protection	1. Whether the water flow is sufficient during heating, and whether the Y-shaped filter is dirty and blocked, resulting in insufficient water flow.
P6	Cooling protection against overheating	1.Check whether the fin heat exchanger of the outdoor unit dissipates heat well during cooling, and whether the condenser is dirty or blocked.
P7	Heat protection against overheating	1. Whether the water flow is sufficient during heating, and whether the Y-shaped filter is dirty and blocked, resulting in insufficient water flow.
P8	Outdoor temperature too high/ too low protection	1. Ambient temperature is too low or too high.

# 14 TECHNICAL SPECIFICATIONS

## Indoor Unit

Indoor unit model	16kW(6kW heater)	16kW(9kW heater)
Power supply	380-415V 3N~50Hz	380-415V 3N~50Hz
Rated input	6100W	9100W
Rated Current	8.9A	13.3A
Norminal capacity	Refer to the technical data	
Dimensions(W×H×D)[mm]	420×790×270	
Packing(W×H×D)[mm]	530×1035×355	
Heat exchanger	Plate heat exchanger	
Electric heater	6kW	9kW
Internal water volume	5.0L	
Rated water pressure	0.3MPa	
Filter mesh	80	
Min. water flow (flow switch)	13L/min	
<b>Pump</b>		
Type	DC inverter	
Max. head	9m	
Power input	5~90W	
<b>Expansion vessel</b>		
Volume	8L	
Max. operating pressure	0.3MPa(g)	
Pre-charge pressure	0.10MPa(g)	
<b>Weight</b>		
Net weight	43.0kg	43.0kg
Gross weight	49.0kg	49.0kg
<b>Connections</b>		
Refrigerant gas/liquid side	Φ15.9/Φ9.52	
Water inlet/outlet	R1"	
Drain connection	DN25	
<b>Operation range</b>		
Outlet water(heating model)	+25 ~ +65°C	
Outlet water(cooling model)	+5 ~ +20°C	
Domestic hot water	+20 ~ +60°C	
Water pressure	0.1 ~ 0.3MPa	

## Outdoor Unit

Outdoor unit model	12kW 3-PH	14kW 3-PH	16kW 3-PH
Power supply	380-415V 3N~50Hz	380-415V 3N~50Hz	380-415V 3N~50Hz
Rated power input	5400W	5800W	6200W
Rated current	10A	11A	12A
Norminal capacity	Refer to the technical data		
Dimensions(W×H×D)[mm]	1010×860×494		
Packing(W×H×D)[mm]	1135×970×530		
Fan motor	DC motor / Horizontal		
Compressor	DC inverter dual rotary		
Heat exchanger	Fin-coil		
<b>Refrigerant</b>			
Type	R32		
Quantity	1840g		
<b>Weight</b>			
Net weight	90.0kg		
Gross weight	102.5kg		
<b>Connections</b>			
Liquid side	Φ9.52		
Gas side	Φ15.9		
Drain connection	DN32		
Max. piping length	30m		
Max. differance in height	20m		
Refrigerant to be added	38g/m		
<b>Operation ambient temperature range</b>			
Heating mode	-25 ~ +35°C		
Cooling mode	-5 ~ +43°C		
Domestic hot water mode	-25 ~ +43°C		



# 15 INFORMATION SERVICING

---

## 1) Checks to the area

Prior to beginning work on systems containing flammable refrigerants, safety checks are necessary to ensure that the risk of ignition is minimized. For repair to the refrigerating system, the following precautions shall be complied with prior to conducting work on the system.

## 2) Work procedure

Works shall be undertaken under a controlled procedure so as to minimise the risk of a flammable gas or vapour being present while the work is being performed.

## 3) General work area

All maintenance staff and others working in the local area shall be instructed on the nature of work being carried out, work in confined spaces shall be avoided. The area around the work space shall be sectioned off. Ensure that the conditions within the area have been made safe by control of flammable material.

## 4) Checking for presence of refrigerant

The area shall be checked with an appropriate refrigerant detector prior to and during work, to ensure the technician is aware of potentially flammable atmospheres. Ensure that the leak detection equipment being used is suitable for use with flammable refrigerants, i.e. no sparking, adequately sealed or intrinsically safe.

## 5) Presence of fire extinguisher

If any hot work is to be conducted on the refrigeration equipment or any associated parts, appropriate fire extinguishing equipment shall be available to hand. Have a dry power or CO<sub>2</sub> fire extinguisher adjacent to the charging area.

## 6) No ignition sources

No person carrying out work in relation to a refrigeration system which involves exposing any pipe work that contains or has contained flammable refrigerant shall use any sources of ignition in such a manner that it may lead to the risk of fire or explosion.

All possible ignition sources, including cigarette smoking, should be kept sufficiently far away from the site of installation, repairing, removing and disposal, during which flammable refrigerant can possibly be released to the surrounding space. Prior to work taking place, the area around the equipment is to be surveyed to make sure that there are no flammable hazards or ignition risks. NO SMOKING signs shall be displayed.

## 7) Ventilated area

Ensure that the area is in the open or that it's adequately ventilated before breaking into the system or conducting any hot work. A degree of ventilation shall continue during the period that the work is carried out. The ventilation should safely disperse any released refrigerant and preferably expel it externally into the atmosphere.

## 8) Checks to the HVAC equipment

Where electrical components are being changed, they shall be fit for the purpose and to the correct specification. At all times the manufacturer's maintenance and service guidelines shall be followed. If in doubt consult the manufacturer's technical department for assistance. The following checks shall be applied to installations using flammable refrigerants:

- The charge size is in accordance with the room size within which the refrigerant containing parts are installed;
- The ventilation machinery and outlets are operating adequately and are not obstructed;
- If an indirect refrigerating circuit is being used, the secondary circuits shall be checked for the presence of refrigerant; marking to the equipment continues to be visible and legible.
- Marking and signs that are illegible shall be corrected;
- Refrigeration pipe or components are installed in a position where they are unlikely to be exposed to any substance which may corrode refrigerant containing components, unless the components are constructed of materials which are inherently resistant to being corroded or are suitably protected against being so corroded.

## 9) Checks to electrical devices

Repair and maintenance to electrical components shall include initial safety checks and component inspection procedures. If a fault exists that could compromise safety, then no electrical supply shall be connected to the circuit until it is satisfactorily dealt with. If the fault cannot be corrected immediately but it is necessary to continue operation, and adequate temporary solution shall be used. This shall be reported to the owner of the equipment so all parties are advised.

Initial safety checks shall include:

- That capacitors are discharged: this shall be done in a safe manner to avoid possibility of sparking;
- That there no live electrical components and wiring are exposed while charging, recovering or purging the system;
- That there is continuity of earth bonding.

## 10) Repairs to sealed components

a) During repairs to sealed components, all electrical supplies shall be disconnected from the equipment being worked upon prior to any removal of sealed covers, etc. If it is absolutely necessary to have an electrical supply to equipment during servicing, then a permanently operating form of leak detection shall be located at the most critical point to warn of a potentially hazardous situation.

b) Particular attention shall be paid to the following to ensure that by working on electrical components, the casing is not altered in such a way that the level of protection is affected. This shall include damage to cables, excessive number of connections, terminals not made to original specification, damage to seals, incorrect fitting of glands, etc.

- Ensure that apparatus is mounted securely.
- Ensure that seals or sealing materials have not degraded such that they no longer serve the purpose of preventing the ingress of flammable atmospheres. Replacement parts shall be in accordance with the manufacturer's specifications.

## NOTE

The use of silicon sealant may inhibit the effectiveness of some types of leak detection equipment. Intrinsically safe components do not have to be isolated prior to working on them.

### 11) Repair to intrinsically safe components

Do not apply any permanent inductive or capacitance loads to the circuit without ensuring that this will not exceed the permissible voltage and current permitted for the equipment in use. Intrinsically safe components are the only types that can be worked on while live in the presence of a flammable atmosphere. The test apparatus shall be at the correct rating. Replace components only with parts specified by the manufacturer. Other parts may result in the ignition of refrigerant in the atmosphere from a leak.

### 12) Cabling

Check that cabling will not be subject to wear, corrosion, excessive pressure, vibration, sharp edges or any other adverse environmental effects. The check shall also take into account the effects of aging or continual vibration from sources such as compressors or fans.

### 13) Detection of flammable refrigerants

Under no circumstances shall potential sources of ignition be used in the searching for or detection of refrigerant leaks. A halide torch (or any other detector using a naked flame) shall not be used.

### 14) Leak detection methods

The following leak detection methods are deemed acceptable for systems containing flammable refrigerants. Electronic leak detectors shall be used to detect flammable refrigerants, but the sensitivity may not be adequate, or may need re-calibration. (Detection equipment shall be calibrated in a refrigerant-free area.) Ensure that the detector is not a potential source of ignition and is suitable for the refrigerant. Leak detection equipment shall be set at a percentage of the LFL of the refrigerant and shall be calibrated to the refrigerant employed and the appropriate percentage of gas (25% maximum) is confirmed. Leak detection fluids are suitable for use with most refrigerants but the use of detergents containing chlorine shall be avoided as the chlorine may react with the refrigerant and corrode the copper pipe-work. If a leak is suspected, all naked flames shall be removed or extinguished. If a leakage of refrigerant is found which requires brazing, all of the refrigerant shall be recovered from the system, or isolated (by means of shut off valves) in a part of the system remote from the leak. Oxygen free nitrogen (OFN) shall then be purged through the system both before and during the brazing process.

### 15) Removal and evacuation

When breaking into the refrigerant circuit to make repairs or for any other purpose conventional procedures shall be used. However, it is important that best practice is followed since flammability is a consideration. The following procedure shall be adhered to:

- Remove refrigerant;
- Purge the circuit with inert gas;
- Evacuate;
- Purge again with inert gas;

Open the circuit by cutting or brazing.

The refrigerant charge shall be recovered into the correct recovery cylinders. The system shall be flushed with OFN to render the unit safe. This process may need to be repeated several times.

Compressed air or oxygen shall not be used for this task.

Flushing shall be achieved by breaking the vacuum in the system with OFN and continuing to fill until the working pressure is achieved, then venting to atmosphere, and finally pulling down to a vacuum. This process shall be repeated until no refrigerant in the system.

When the final OFN charge is used, the system shall be vented down to atmospheric pressure to enable work to take place.

This operation is absolutely vital if brazing operations on the pipe-work are to take place.

Ensure that the outlet for the vacuum pump is not closed to any ignition sources and there is ventilation available.

### 16) Charging procedures

In addition to conventional charging procedures, the following requirements shall be followed:

Ensure that contamination of different refrigerants does not occur when using charging equipment. Hoses or lines shall be as short as possible to minimize the amount of refrigerant contained in them.

- Cylinders shall be kept upright.
- Ensure that the refrigeration system is earthed prior to charging the system with refrigerant.
- Label the system when charging is complete (if not already).
- Extreme care shall be taken not to overfill the refrigeration system.
- Prior to recharging the system it shall be pressure tested with OFN. The system shall be leak tested on completion of charging but prior to commissioning. A follow up leak test shall be carried out prior to leaving the site.

### 17) Decommissioning

Before carrying out this procedure, it is essential that the technician is completely familiar with the equipment and all its detail.

It is recommended good practice that all refrigerants are recovered safely. Prior to the task being carried out, an oil and refrigerant sample shall be taken.

In case analysis is required prior to re-use of reclaimed refrigerant. It is essential that electrical power is available before the task is commenced.

- a) Become familiar with the equipment and its operation.
- b) Isolate system electrically.
- c) Before attempting the procedure ensure that:
  - Mechanical handling equipment is available, if required, for handling refrigerant cylinders;
  - All personal protective equipment is available and being used correctly;
  - The recovery process is supervised at all times by a competent person;
  - Recovery equipment and cylinders conform to the appropriate standards.
- d) Pump down refrigerant system, if possible.
- e) If a vacuum is not possible, make a manifold so that refrigerant can be removed from various parts of the system.
- f) Make sure that cylinder is situated on the scales before recovery takes place.
- g) Start the recovery machine and operate in accordance with manufacturer's instructions.
- h) Do not overfill cylinders. (No more than 80% volume liquid charge).
- i) Do not exceed the maximum working pressure of the cylinder, even temporarily.
- j) When the cylinders have been filled correctly and the process completed, make sure that the cylinders and the equipment are removed from site promptly and all isolation valves on the equipment are closed off.
- k) Recovered refrigerant shall not be charged into another refrigeration system unless it has been cleaned and checked.

#### 18) Labeling

Equipment shall be labeled stating that it has been de-commissioned and emptied of refrigerant. The label shall be dated and signed. Ensure that there are labels on the equipment stating the equipment contains flammable refrigerant.

#### 19) Recovery

When removing refrigerant from a system, either for service or decommissioning, it is recommended good practice that all refrigerants are removed safely.

When transferring refrigerant into cylinders, ensure that only appropriate refrigerant recovery cylinders are employed. Ensure that the correct numbers of cylinders for holding the total system charge are available. All cylinders to be used are designated for the recovered refrigerant and labeled for that refrigerant (i.e. special cylinders for the recovery of refrigerant). Cylinders shall be completed with pressure relief valve and associated shut-off valves in good working order.

Empty recovery cylinders are evacuated and, if possible, cooled before recovery occurs. The recovery equipment shall be in good working order with a set of instructions concerning the equipment that is at hand and shall be suitable for the recovery of flammable refrigerants. In addition, a set of calibrated weighing scales shall be available and in good working order.

Hoses shall be completed with leak-free disconnect couplings and in good condition. Before using the recovery machine, check that it is in satisfactory working order, has been properly maintained and that any associated electrical components are sealed to prevent ignition in the event of a refrigerant release. Consult manufacturer if in doubt.

The recovered refrigerant shall be returned to the refrigerant supplier in the correct recovery cylinder, and the relevant Waste Transfer note arranged. Do not mix refrigerants in recovery units and especially not in cylinders.

If compressors or compressor oils are to be removed, ensure that they have been evacuated to an acceptable level to make certain that flammable refrigerant does not remain within the lubricant. The evacuation process shall be carried out prior to returning the compressor to the suppliers. Only electric heating to the compressor body shall be employed to accelerate this process. When oil is drained from a system, it shall be carried out safely.

#### 20) Transportation, marking and storage for units.

Transport of equipment containing flammable refrigerants Compliance with the transport regulations.

Marking of equipment using signs Compliance with local regulations.

Disposal of equipment using flammable refrigerants Compliance with national regulations.

Storage of equipment/appliances.

The storage of equipment should be in accordance with the manufacturer's instructions.

Storage of packed (unsold) equipment.

Storage package protection should be constructed such that mechanical damage to the equipment inside the package will not cause a leak of the refrigerant charge.

The maximum number of pieces of equipment permitted to be stored together will be determined by local regulations.

